

Models

KT-150C KT-300D KT-500D KT-850D

Features

- Full pumping speed down to 1 Torr
- Can operate continuously (at any pressure) up to 100 Torr
- Ultimate pressure 10 Microns (McLeod Gauge)
- Adjustable gas ballast permits handling of condensable vapors
- No metal to metal contact in pumping chamber
- Unequaled durability, even in dirty applications
- Compact footprint design
- Simple installation, no special preparations required
- Triplex piston design provides quiet, vibration-free operation
- Integral, positive lubrication system ensures reliable lubrication at all pressure levels
- Optional factory-mounted oil filtration system lowers maintenance costs and increases uptime



Specifications

	MODEL	KT-150C	KT-300D	KT-500D	KT-850D
Nominal Displacement	CFM / m ³ /h	150 / 255	300 / 510	500 / 850	778 / 1322
Motor	HP / kW	7.5 / 6	15 / 11	30 / 22	40 / 30
Cooling Water @ 60° F(15.5°C) – 45 psig max	GPM / L/min	1 / 4	1.5 / 8	3 / 12	4 / 16
Oil Capacity	gal / Liters	6 / 23	10 / 38	15 / 57	28 / 106
Pump Weight	Lbs. / kg	800 / 364	1525 / 693	2625 / 1200	4175 / 1900
Maximum Gas Ballast (GB) Flow	CFM / m ³ /h	11 / 18	20 / 34	34 / 58	62 / 105
Blank off (at 5% Gas Ballast)	Torr / mbar	2.0 / 2.6	2.0 / 2.6	2.0 / 2.6	2.0 / 2.6
Ultimate Pressure	Torr / mbar	0.010 / 0.013	0.010 / 0.013	0.010 / 0.013	0.010 / 0.013
Noise Level at 0.1 Torr	dB(A)	71	72	73	75

Typical Pumping Speed Curves

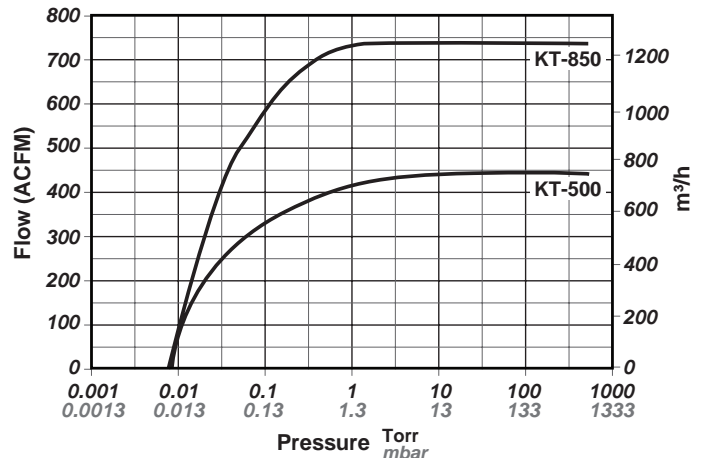
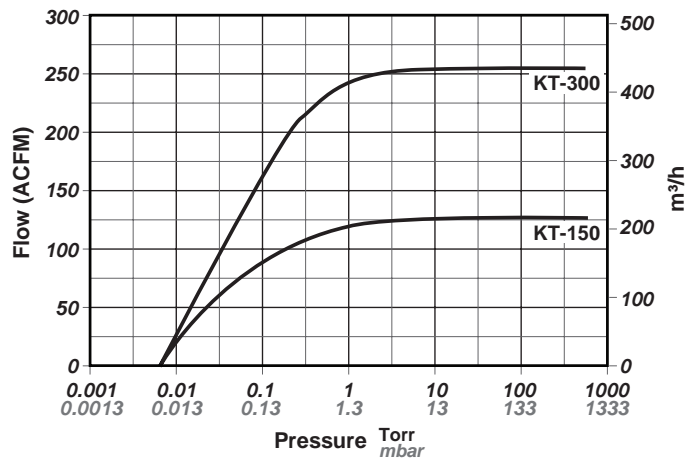

Dimensions

Values shown are approximate and should not be used for construction.

Certified drawings are available through your local Tuthill Vacuum & Blower Systems Sales Professional.

Models KT-150C, KT300D, KT-500D, KT-850D

KT-150C Note: Illustration does not accurately reflect features of KT-150C.

Water Inlet is position R and Water Outlet is position P.

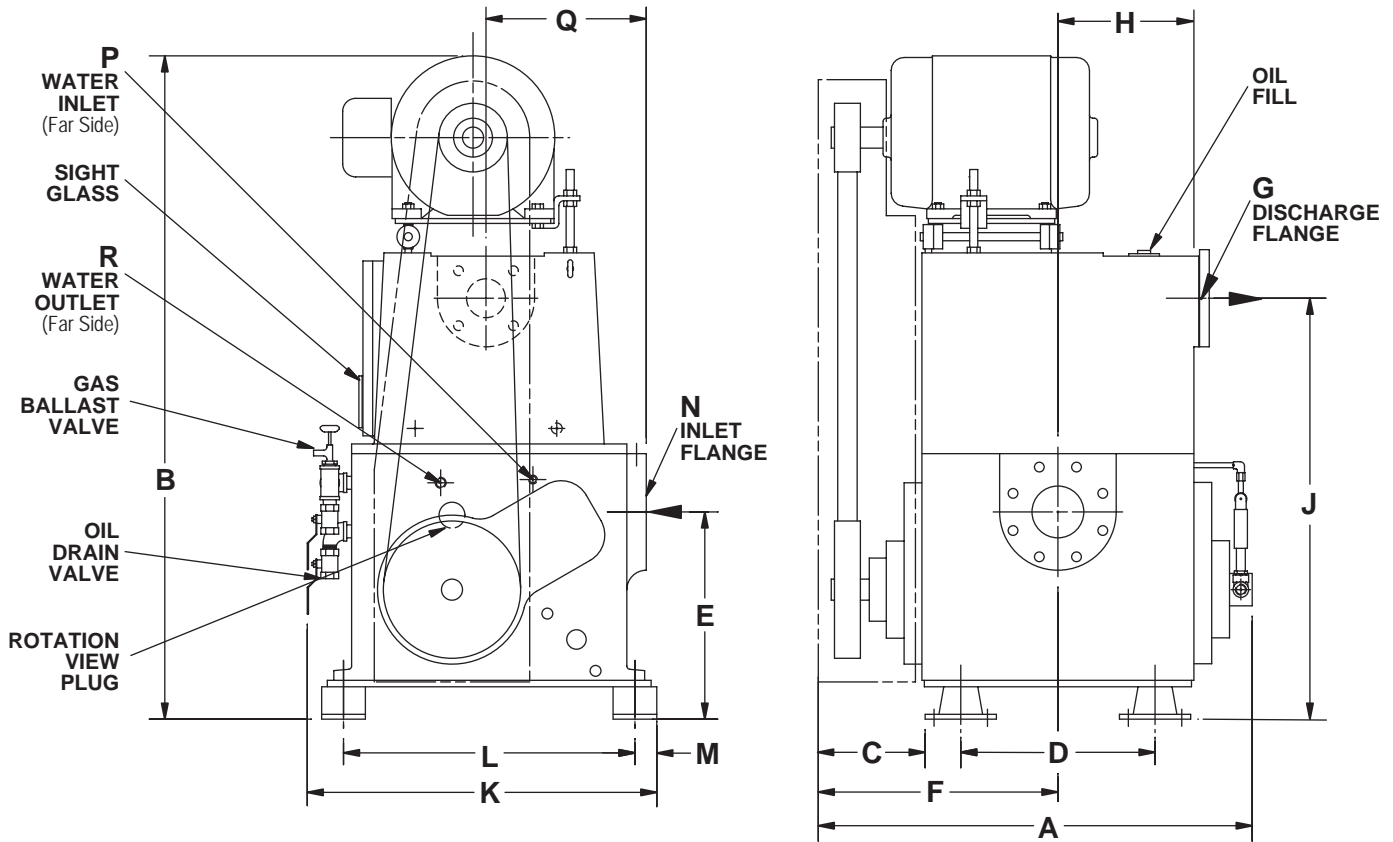

in. / mm	A	B	C	D	E	F	G DISCHARGE	H	J	K	L	M	N INLET	P	Q	R
KT-150C	26 660	43 1092	6.53 166	11.75 298	12.63 321	14.5 368	2" ANSI	7.25 184	28.2 716	22.75 578	19.13 486	1.19 30	3" ANSI	3/8 outlet	9.38 238	1/4 inlet
KT-300D	33.5 851	51.25 1302	8.25 210	15 381	16 406	18.5 470	3" ANSI	10.88 276	32.5 826	27 686	22.5 572	1.69 43	4" ANSI	3/8	12.38 314	1/2
KT-500D	37.25 946	63.13 1604	10.38 264	17 432	21.5 546	21.25 540	4" ANSI	11.75 298	41 1041	32.32 821	28 711	1.38 35	6" ANSI	3/8	15.38 391	1/2
KT-850D	48.5 1232	69.69 1770	12 305	24.75 629	24.25 616	25.75 654	5" ANSI	15.5 394	46 1168	38.06 967	33 838	1.38 29	8" ANSI	3/8	18.25 464	1/2

Your Local Tuthill Vacuum Blower Systems Sales Professional:



Tuthill Vacuum & Blower Systems
 4840 West Kearney Street
 Springfield, Missouri USA 65803-8702
 o 417.865.8715 800.825.6937 f 417.865.2950
 tuthillvacuumblower.com

