

KINNEY® KD/KDH™

Rotary Piston, Single-Stage Vacuum Pumps

Models: KD-30 KD-50 KDH-130 KDH-150

Features

- Absolute pressures down to the low micron range
- Full pumping speed down to 1 Torr
- Long-life operation due to no metal-to-metal contact in the pumping chamber
- High resistance to abrasion and corrosion
- No small orifices to plug up
- KD pumps include integral oil mist eliminator
- Adjustable gas ballast permits handling of condensable vapors



Models KD-30, KD-50

These pumps have a single shaft and two sets of cams and pistons mounted 180 degrees apart operating in parallel.

Models KDH-130, KDH-150

In addition to the features of the KD series the KDH-130, KDH 150 includes a water jacket for cooler operating temperatures (Air-cooling optional for continuous operating pressures <10 Torr*).

Specifications

MODEL	CAPACITY ACFM / m ³ /h	HP / kW	RPM	OIL CAPACITY GAL / Liter	WATER (80°F) GPM / L/min	GAS BALLAST FLOW (MAX) %	BLANK-OFF (5% GAS) Torr / mbar	ULTIMATE PRESSURE MICRONS / mbar
KD-30	33 / 56	1.5 / 1.11	571	1 / 3.78	Air-cooled	8%	1.5 / 2	10 / 0.013
KD-50	52 / 88	2 / 1.5	900	3 / 11.34		6%		
KDH-130	134 / 227	5 / 3.7	546	6 / 22.68	.75* / 3	1.0 / 1.3		
KDH-150	165 / 280	7.5 / 5.6	684		.75 / 3		5%	

* Air Cooling Optional

Typical Pumping Speed Curves

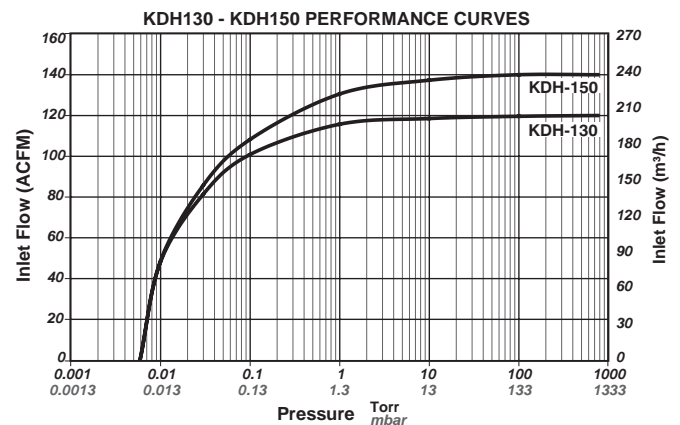
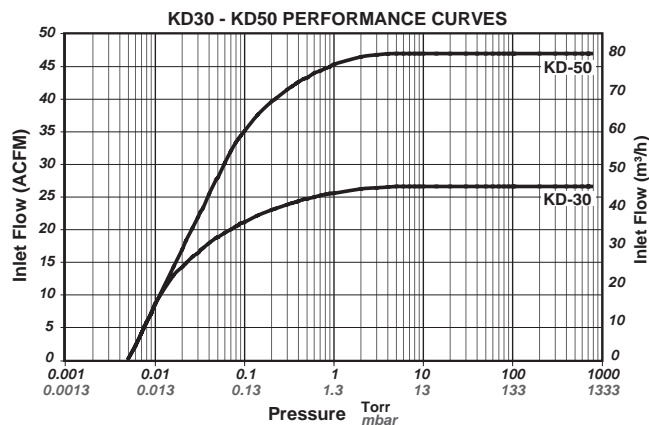

Dimensions:

Values shown are approximate and should not be used for construction. Certified drawings are available through your local Tuthill Vacuum & Blower Systems Sales Professional. Dimensions are shown in inches and *millimeters*.

Models

KD-30

KD-50

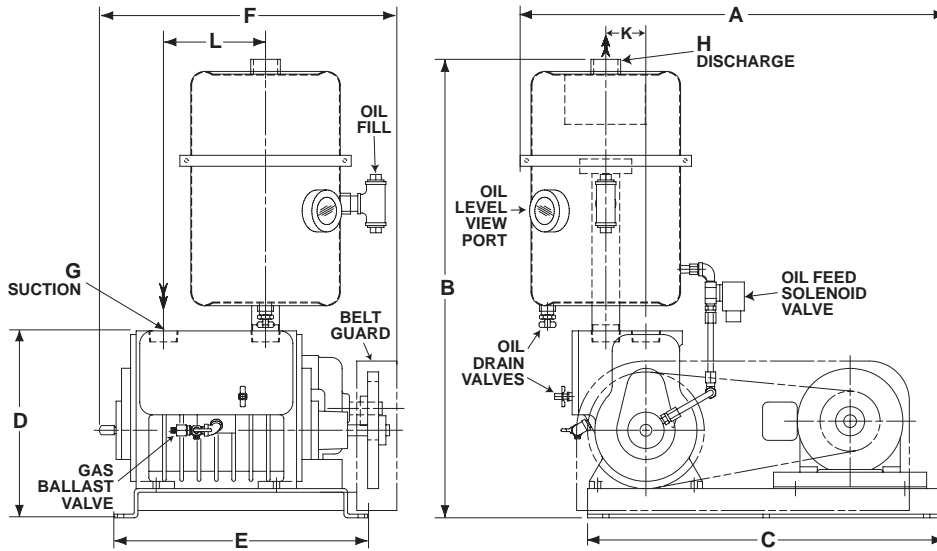

MODEL	A	B	C	D	E	F	G	H	K	L	WEIGHT LBS / kg
KD-30	27.75 <i>705</i>	29 <i>737</i>	24.50 <i>622</i>	12.81 <i>325</i>	17.38 <i>441</i>	20 <i>508</i>	1½" NPT	1¼" NPT	2.75 <i>70</i>	7.00 <i>178</i>	200 <i>91</i>
KD-50	29.13 <i>740</i>	31.50 <i>800</i>									230 <i>104</i>

Models

KDH-130

KDH-150

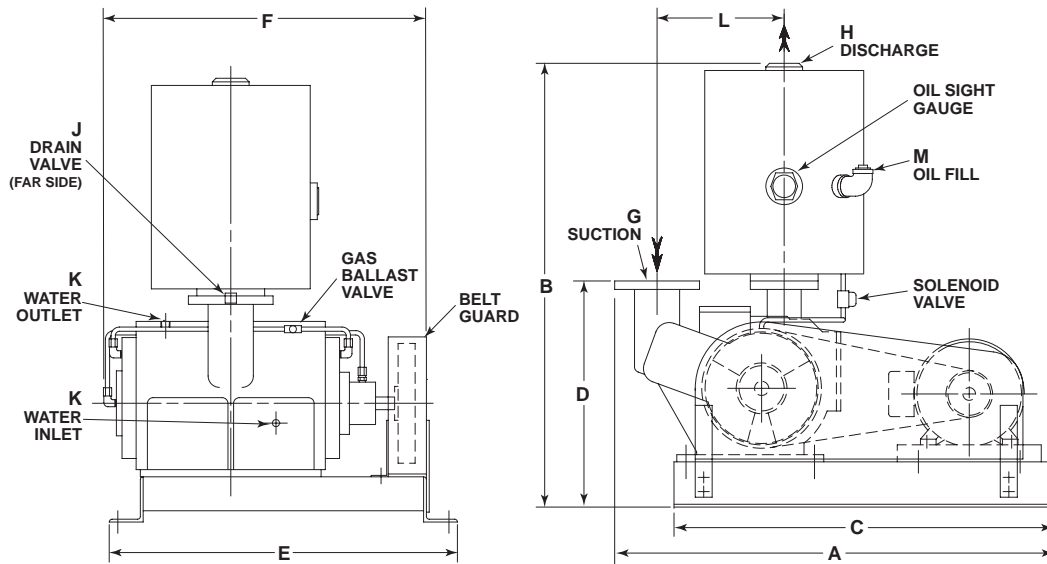

MODEL	A	B	C	D	E	F	G	H	J	K	L	M	WEIGHT LBS / kg
KDH-130	38.88 <i>987</i>	39.25 <i>997</i>	33.63 <i>854</i>	20 <i>508</i>	30.81 <i>783</i>	28.68 <i>719</i>	3" FLG	2" NPT	½" NPT	¾" NPT	11.25 <i>286</i>	1" NPT	755 <i>331</i>
KDH-150													840 <i>381</i>

Your Local Tuthill Vacuum & Blower Systems Sales Professional:



Tuthill Vacuum & Blower Systems
 4840 West Kearney Street
 Springfield, Missouri USA 65803-8702
 o 417.865.8715 800.825.6937 f 417.865.2950
 tuthillvacuumblower.com

