

### Models

KC-5 KC-8 KC-15

### Features

- High pumping speed at pressures below 10 microns; much lower than attainable with single stage pumps
- Ultimate Vacuum: 0.2 microns (McLeod Gauge)
- Positive pressure lubrication assures operation at any pressure up to atmospheric pressure
- Adjustable gas ballast permits handling of condensable vapors
- No metal-to-metal contact in pumping chamber
- Unequaled durability, even in dirty applications



### Specifications

MODEL	NOMINAL DISPLACEMENT ACFM / m <sup>3</sup> /h	MOTOR HP / kW	RPM	OIL CAPACITY Quarts/Liters	MAX. GAS BALLAST FLOW %	GAS BALLAST PRESSURE Torr / mbar	ULTIMATE PRESSURE MICRONS / mbar	NOISE LEVEL AT 0.1 TORR (0.13 mbar) dB(A)
KC-5	5 / 8.5	0.33 / 0.25	638	0.8 / 0.76	15	0.02 / 0.027	0.2 / 0.00027	75
KC-8	8 / 13.6	1-Phase: 0.75 / 0.56 3-Phase: 0.5 / 0.37	1022	0.8 / 0.76	15	0.02 / 0.027	0.2 / 0.00027	78
KC-15	15 / 25.5	1 / 0.75	572	3.0 / 2.84	15	0.02 / 0.027	0.2 / 0.00027	75

### Typical Pumping Speed Curves

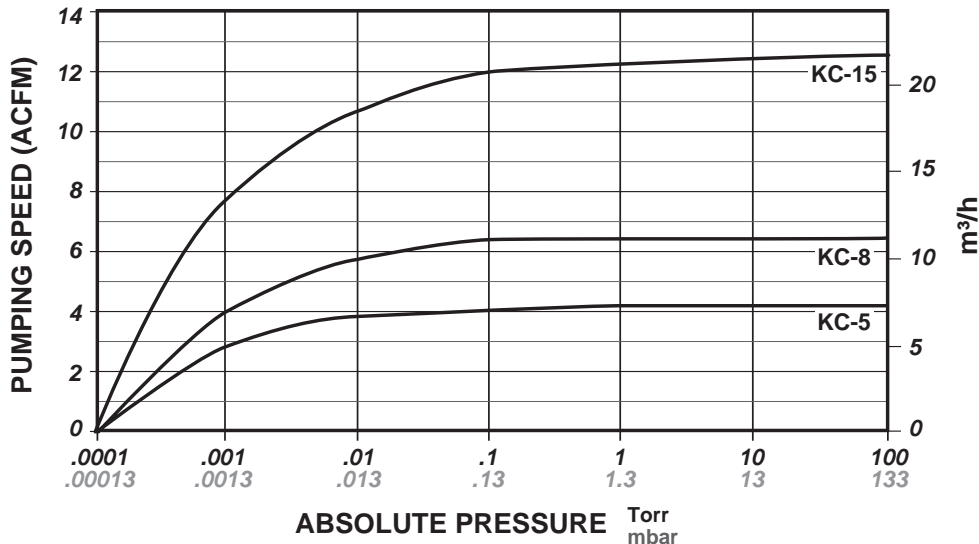

## Dimensions

Values shown are approximate and should not be used for construction.

Certified drawings are available through your local Tuthill Vacuum & Blower Systems Sales Professional.

## Models: KC-5, KC-8, KC-15

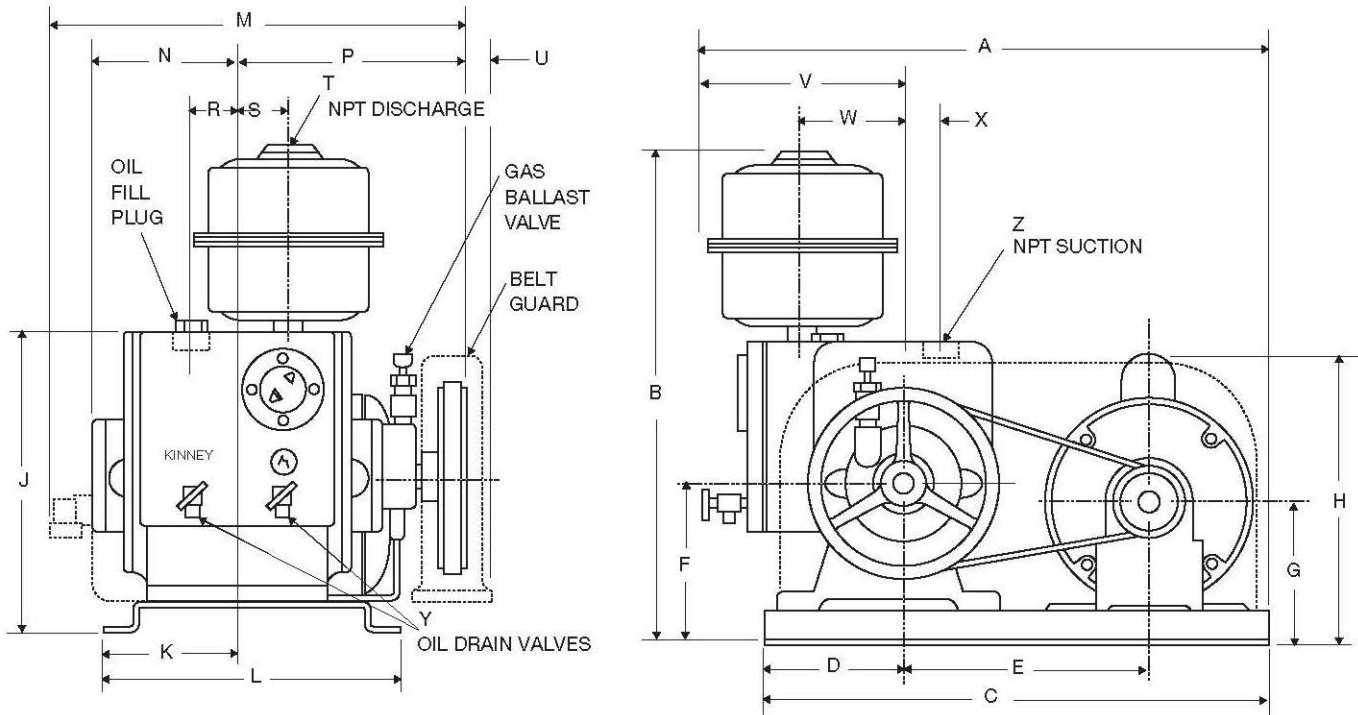

in. mm	A	B	C	D	E	F	G	H	J	K	L
KC-5	18.00	17.88	16.50	4.57	8.00	5.06	4.50	(9.88)	9.69	4.38	9.75
KC-8	457	454	419	116	203	129	114	251	246	111	248
KC-15	20.25	24.31	17.00	4.00	9.00	6.00	5.50	(10.00)	12.81	8.00	15.75
	514	617	432	101	229	152	140	254	325	203	400

in. mm	M	N	P	R	S	T	U	V	W	X	Z	Weight lbs. / kg
KC-5	14.13	4.38	7.50	1.50	1.75	3/4"	1.00	7.13	3.13	1.19	1.00	115 / 52
KC-8	359	111	191	38	44	-	25	181	80	30	-	120 / 54
KC-15	17.94	7.25	10.69	3.00	3.50	1 1/2"	0.56	7.25	3.75	-	2.00	210 / 95
	456	184	272	76	89	-	14	184	95	-	-	

Your Local Tuthill Vacuum Blower Systems Sales Professional:



Tuthill Vacuum & Blower Systems

4840 West Kearney Street

Springfield, Missouri USA 65803-8702

o 417.865.8715 800.825.6937 f 417.865.2950

tuthillvacuumblower.com



TH-023 03/20