

Uno 30 M, 1-phase motor, 100–110 V, 50 Hz | 100–120 V, 60 Hz

PFEIFFER  **VACUUM**



Similar Image

Uno 30 M, 1-phase motor, 100–110 V, 50 Hz | 100–120 V, 60 Hz

- Single-stage, high-performance rotary vane pump with a pumping speed 30 m³/h at 50 Hz / 35 m³/h at 60 Hz
- Magnetically coupled
- With Single-phase motor
- Integrated gas ballast and safety valve
- For all low and medium vacuum applications
- Special feature: Various motor voltages for worldwide employment
- Other motor voltages available on request

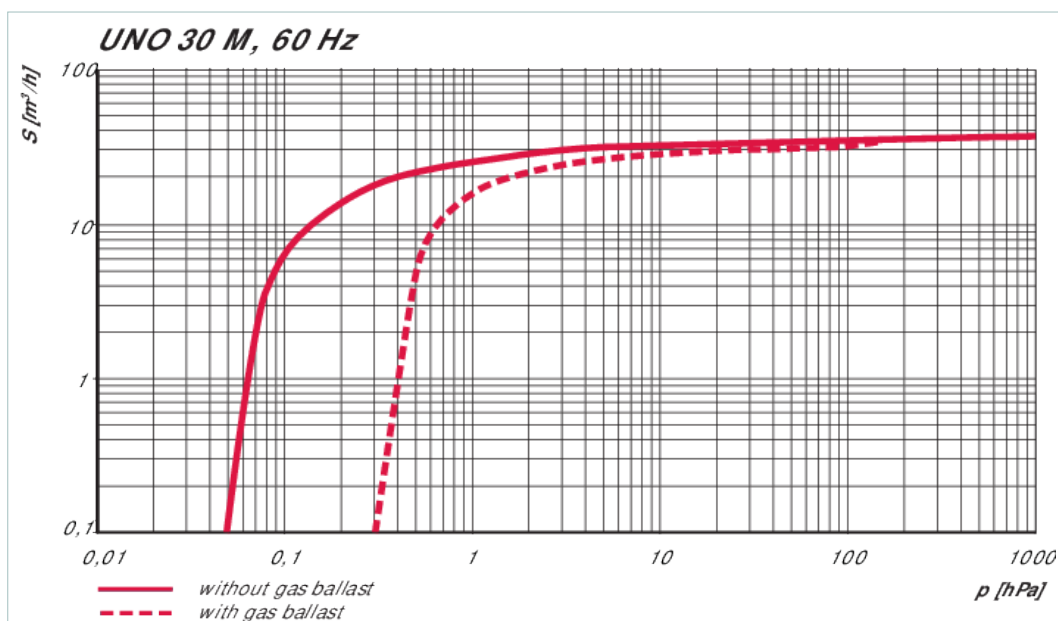
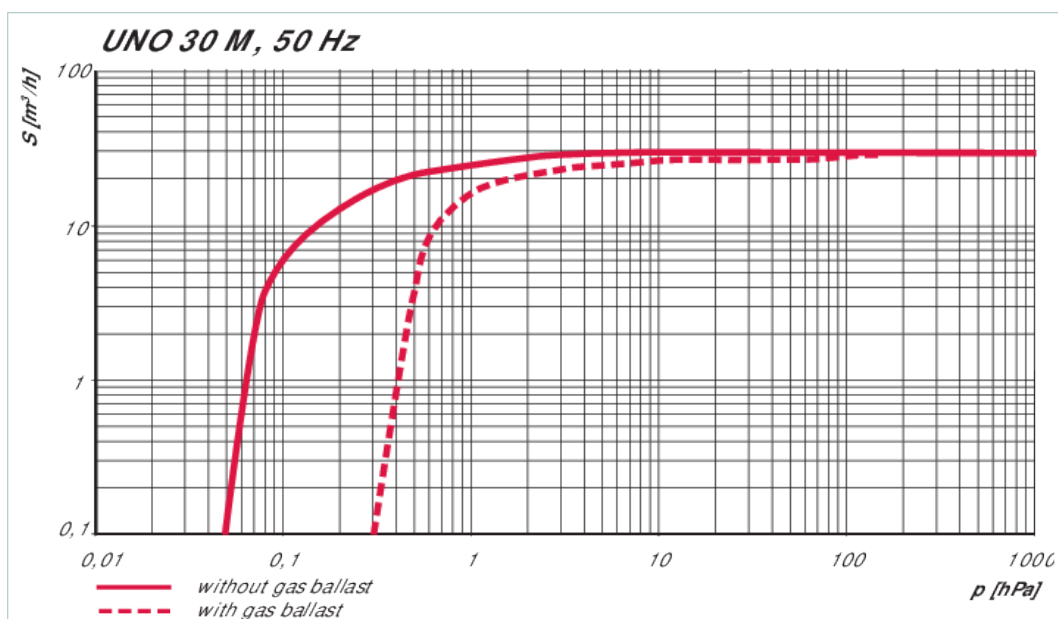

Dimensions

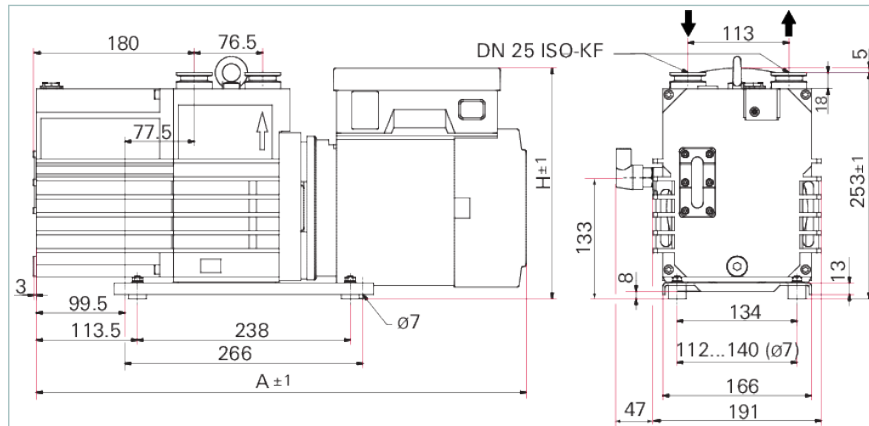

A	551 mm
H	262 mm

Technical Data	Uno 30 M, 1-phase motor, 100–110 V, 50 Hz 100–120 V, 60 Hz
Pumping speed at 60 Hz	35 m ³ /h 20.6 cfm 583.33 l/min
Pumping speed at 50 Hz	30 m ³ /h 17.66 cfm 500 l/min
Protection category	IP54
Final pressure with gas ballast	3 · 10 ⁻¹ hPa 2.25 · 10 ⁻¹ Torr 3 · 10 ⁻¹ mbar
Final pressure without gas ballast	5 · 10 ⁻² hPa 3.75 · 10 ⁻² Torr 5 · 10 ⁻² mbar
Connection flange (in)	DN 25 ISO-KF
Connection flange (out)	DN 25 ISO-KF
Rated power 50 Hz	0.75 kW
Rated power 60 Hz	0.9 kW
Motor version	1-ph motor
Mains cable	Yes, US power cable, length 2 m
Cable length	2 m
Cooling method, standard	Air
Ambient temperature	15–40 °C 59–104 °F 288–313 K
Exhaust pressure, max.	1,500 hPa 1,125 Torr 1,500 mbar
Exhaust pressure, min.	250 hPa 187.5 Torr 250 mbar
Emission sound pressure level without gas ballast at 50 Hz	62 dB(A)
Operating fluid	P3
Operating fluid amount	1.1 l
Rotation speed at 50 Hz	1,500 rpm 1,500 min ⁻¹
Rotation speed at 60 Hz	1,800 rpm 1,800 min ⁻¹
Leak rate safety valve	1 · 10 ⁻⁵ Pa m ³ /s 7.5 · 10 ⁻⁵ Torr l/s 1 · 10 ⁻⁴ mbar l/s
Weight	43 kg 94.8 lb

Order number	Uno 30 M	PK D54 707
--------------	----------	------------

Accessories	
Heating Heating rods for zeolite traps (ZFO)	
Heating rod for ZFO 025, 220 V, 50/60 Hz	PK Z90 012 A
Monitoring Pressure switches	
Oil pressure switch for Duo 5/10/20 M and Penta 20/35	PK 196 484 -T
Other	
Cold Trap, LN2, angled, DN 25 ISO-KF, 4" body, stainless steel / FPM	FTNA-4-1002-NWB
Protection Activated carbon filters	
FAK 025, activated carbon filter	PK Z30 006
Protection Catalyzer traps	
URB 025, catalytic trap, 230 V	PT U10 760
URB 025, catalytic trap, 115 V	PT U10 761
Protection Condensate separators	
KAS 25 L, condensate separator for pumping speeds up to 35 m ³ /h	PK Z10 033
Protection Dust separators/Inlet particle filters	
SAS 25, DN 25 ISO-KF, polyester filter	PK Z60 508
Protection Motor protection	
PTC-resistor tripping device for motor protection 220 – 240 V AC	P 4768 052 FQ
Protection Oil mist eliminators	
OME 25 ML, oil mist separator for pumping speeds of up to 30 m ³ /h	PK Z40 158
OME 25 M XL, oil mist separator for pumping speeds up to 42 m ³ /h	PK Z40 160
Protection Oil return units from oil mist eliminators	
Oil return unit ODK from OME 25 MXL to Uno 30 M	PK 196 944 -T
Protection Sorption traps	
Sorption trap ST 25 S	104107
Consumables	
P3, mineral oil, 1 l	PK 001 106 -T
P3, mineral oil, 5 l	PK 001 107 -T
P3, mineral oil, 20 l	PK 001 108 -T
D1, synthetic diester based oil, 1 l	PK 005 875 -T
D1, synthetic diester based oil, 5 l	PK 005 876 -T
D1, synthetic diester based oil, 20 l	PK 005 877 -T

VACUUM SOLUTIONS FROM A SINGLE SOURCE

Pfeiffer Vacuum stands for innovative and custom vacuum solutions worldwide, technological perfection, competent advice and reliable service.

COMPLETE RANGE OF PRODUCTS

From a single component to complex systems:

We are the only supplier of vacuum technology that provides a complete product portfolio.

COMPETENCE IN THEORY AND PRACTICE

Benefit from our know-how and our portfolio of training opportunities!

We support you with your plant layout and provide first-class on-site service worldwide.

Are you looking for a
perfect vacuum solution?
Please contact us:

Pfeiffer Vacuum GmbH
Headquarters · Germany
T +49 6441 802-0
info@pfeiffer-vacuum.de

www.pfeiffer-vacuum.com

All data subject to change without prior notice.

PFEIFFER  **VACUUM**