



Duo 1.6, single-phase motor, 220–240 V, 50/60 Hz



Similar Image

Duo 1.6, single-phase motor, 220–240 V, 50/60 Hz

- Dual-stage, high-performance rotary vane pump with a pumping speed of 1.25 m³/h at 50 Hz / 1.50 m³/h at 60 Hz
- With single-phase motor with C14 connector plug inside the motor electronic box
- Integrated gas ballast and safety valve
- OME oil return device is included with the pump
- For all low and medium vacuum applications
- Special feature: various motor voltages for wide range of application fields

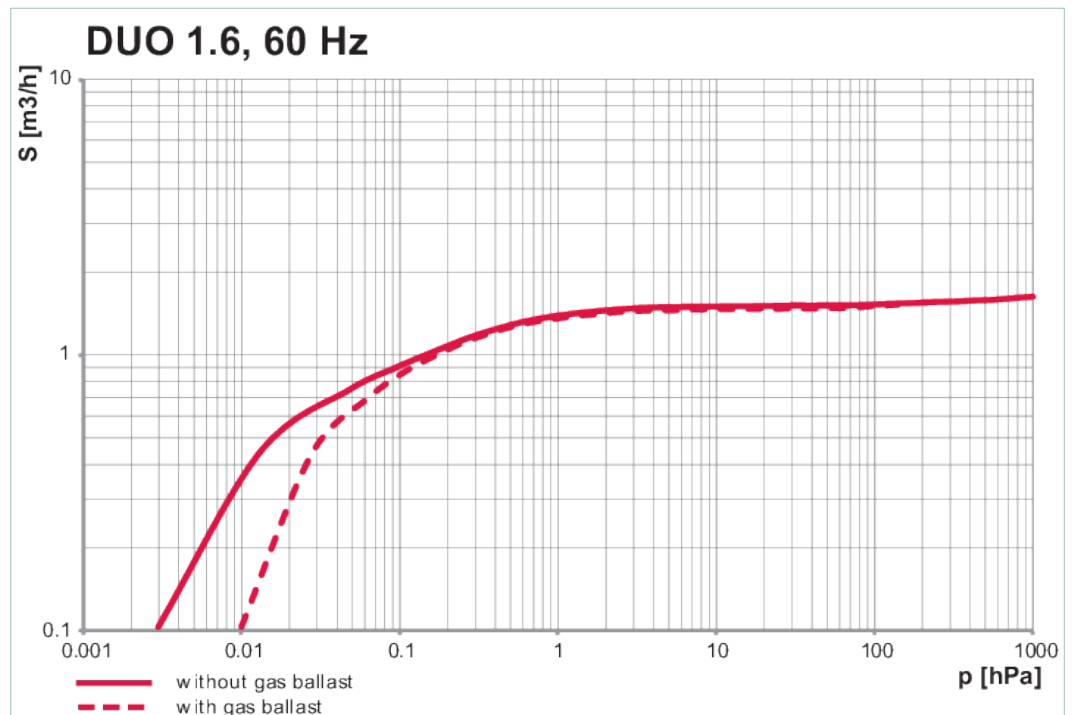
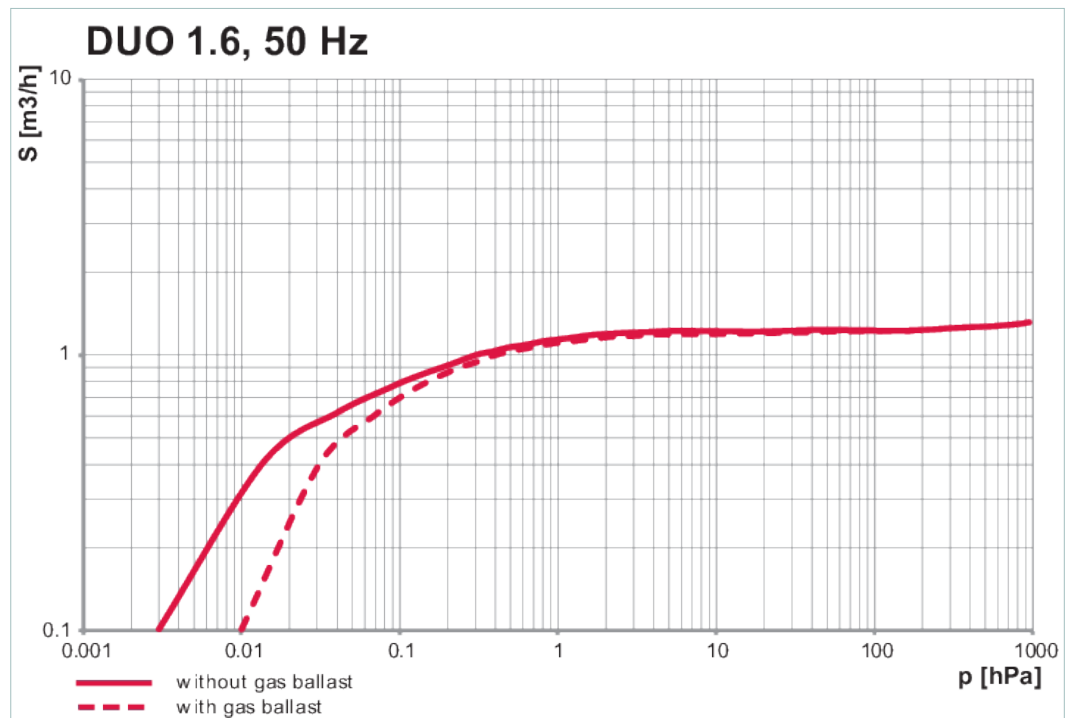

Dimensions

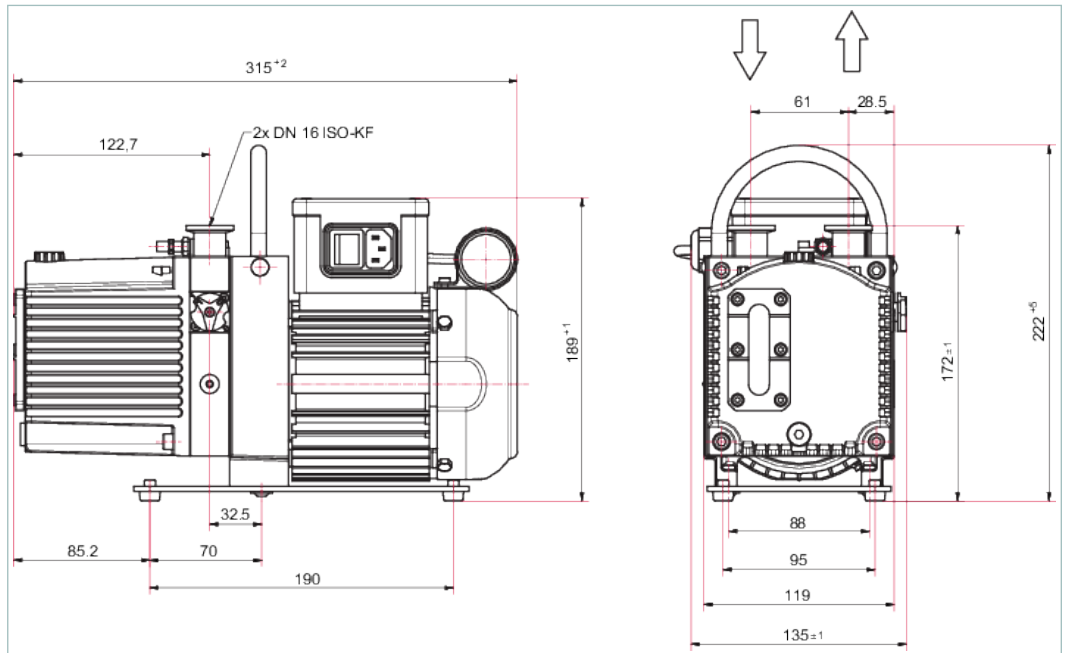

Technical Data	Duo 1.6, single-phase motor, 220–240 V, 50/60 Hz
Connection flange (in)	DN 16 ISO-KF
Connection flange (out)	DN 16 ISO-KF
Pumping speed at 50 Hz	1.25 m ³ /h 0.74 cfm 20.83 l/min
Pumping speed at 60 Hz	1.5 m ³ /h 0.88 cfm 25 l/min
Final pressure with gas ballast	1 · 10 ⁻² hPa 7.5 · 10 ⁻³ Torr 1 · 10 ⁻² mbar
Final pressure without gas ballast	3 · 10 ⁻³ hPa 2.25 · 10 ⁻³ Torr 3 · 10 ⁻³ mbar
Exhaust pressure, min.	Atmospheric pressure
Exhaust pressure, max.	1,500 hPa 1,125 Torr 1,500 mbar
Water vapor capacity 50 Hz	15 g/h
Water vapor capacity 60 Hz	20 g/h
Water vapor tolerance at 50 Hz	15 hPa 11.25 Torr 15 mbar
Water vapor tolerance at 60 Hz	15 hPa 11.25 Torr 15 mbar
Rotation speed at 50 Hz	1,500 rpm 1,500 min ⁻¹
Rotation speed at 60 Hz	1,800 rpm 1,800 min ⁻¹
Cooling method, standard	Air
Motor	Yes
Motor protection	Bimetal
Motor version	1-ph motor
Ambient temperature	12–40 °C 53.6–104 °F 285–313 K
Continuous gas temperature, max.	40 °C 104 °F 313 K
Emission sound pressure level without gas ballast at 50 Hz	42 dB(A)
Emission sound pressure level without gas ballast at 60 Hz	44 dB(A)
Mains requirement: voltage (range)	± 10 %
Mains connection: voltage 50 Hz	220 – 240 V
Mains connection: voltage 60 Hz	220 – 240 V
Recommended electric fuse protection on-site	2.5 / A
Mains cable	, C14-plug inside the terminal box
Gas ballast flow	180 l/h
Gas ballast	Yes
Operating fluid	P3

Technical Data	Duo 1.6, single-phase motor, 220–240 V, 50/60 Hz
Operating fluid amount	0.4 l
Leak rate safety valve	$\leq 1 \cdot 10^{-5}$ Pa m ³ /s $\leq 7.5 \cdot 10^{-5}$ Torr l/s $\leq 1 \cdot 10^{-4}$ mbar l/s
Dimensions (L x W x H)	317 x 136 x 190 mm 12.48 x 5.35 x 7.48 inch
Rated power 50 Hz	0.075 kW
Rated power 60 Hz	0.09 kW
Protection category	IP40
Weight	9.6 kg 21.16 lb

Order number	
Duo 1.6	PK D56 712

Accessories	
Cables Mains cables / Power cords	
Mains cable 230 V with safety plug, right angle IEC 320/C13 socket, 2 m	PK 050 109
Mains cable, 115 V, with NEMA plug to Euro C13 socket (angled), 2 m	PK 050 110
Mains cable 115/230 V without plug, rubber connector (right angle), 3 m	PK 050 111
Flanges/Ports Blank flanges	
Blank flange gas ballast valve with O-ring and screws	PK 007 002 -T
Monitoring Operations monitoring units	
Operations monitoring unit 3 for Duo 1.6/3/6/11 and Duo 5/10/20 M	PK 196 146 -T
Operations monitoring unit 2 for Duo 1.6/3/6/11 and Duo 5/10/20 M	PK 196 147 -T
Operations monitoring unit 1 for Duo 1.6/3/6/11 and Duo 5/10/20 M	PK 196 148 -T
Operating Fluids Mineral oil	
P3, mineral oil, 1 l	PK 001 106 -T
P3, mineral oil, 0.5 l	PK 001 136 -T
Other	
Gas ballast valve with dosing spindle and inert gas connection	PK 195 666 -U
Protection Condensate separators	
KAS 16, condensate separator for pumping speeds from 1.6 to 12 m ³ /h	PK Z10 003
Protection Dust separators/Inlet particle filters	
SAS 16, DN 16 ISO-KF, polyester filter	PK Z60 506
Protection Oil mist eliminators	
OME 16 S, oil mist separator for pumping speeds up to 12 m ³ /h	PK Z40 000
OME 16 M, oil mist separator for pumping speeds up to 12 m ³ /h	PK Z40 003
Protection Oil return units from oil mist eliminators	
Oil return unit from OME 16 S/16 C to Duo 1.6/Duo 3/Duo 6/Duo 11/Uno 6	PK 005 986 -T
Oil return unit from OME 16 M to Duo 1.6, 3, 6, 11, Uno 6	PK 006 080 -T
Protection Sorption traps	
ZFO 16, zeolite trap	PK Z70 003
Valves Gas ballast valves, magnetic	
Gas ballast valve with solenoid valve 24 V DC	PK 194 343 -U

VACUUM SOLUTIONS FROM A SINGLE SOURCE

Pfeiffer Vacuum stands for innovative and custom vacuum solutions worldwide, technological perfection, competent advice and reliable service.

COMPLETE RANGE OF PRODUCTS

From a single component to complex systems:

We are the only supplier of vacuum technology that provides a complete product portfolio.

COMPETENCE IN THEORY AND PRACTICE

Benefit from our know-how and our portfolio of training opportunities!

We support you with your plant layout and provide first-class on-site service worldwide.

Are you looking for a
perfect vacuum solution?
Please contact us:

Pfeiffer Vacuum GmbH
Headquarters · Germany
T +49 6441 802-0
info@pfeiffer-vacuum.de

www.pfeiffer-vacuum.com

All data subject to change without prior notice.

PFEIFFER  **VACUUM**