

CO6

E and DK

Rotary Piston Vacuum Pumps

Single- and two-stage, oil-sealed,
200 - 250 m³ x h⁻¹ (117.8 - 147 cfm)

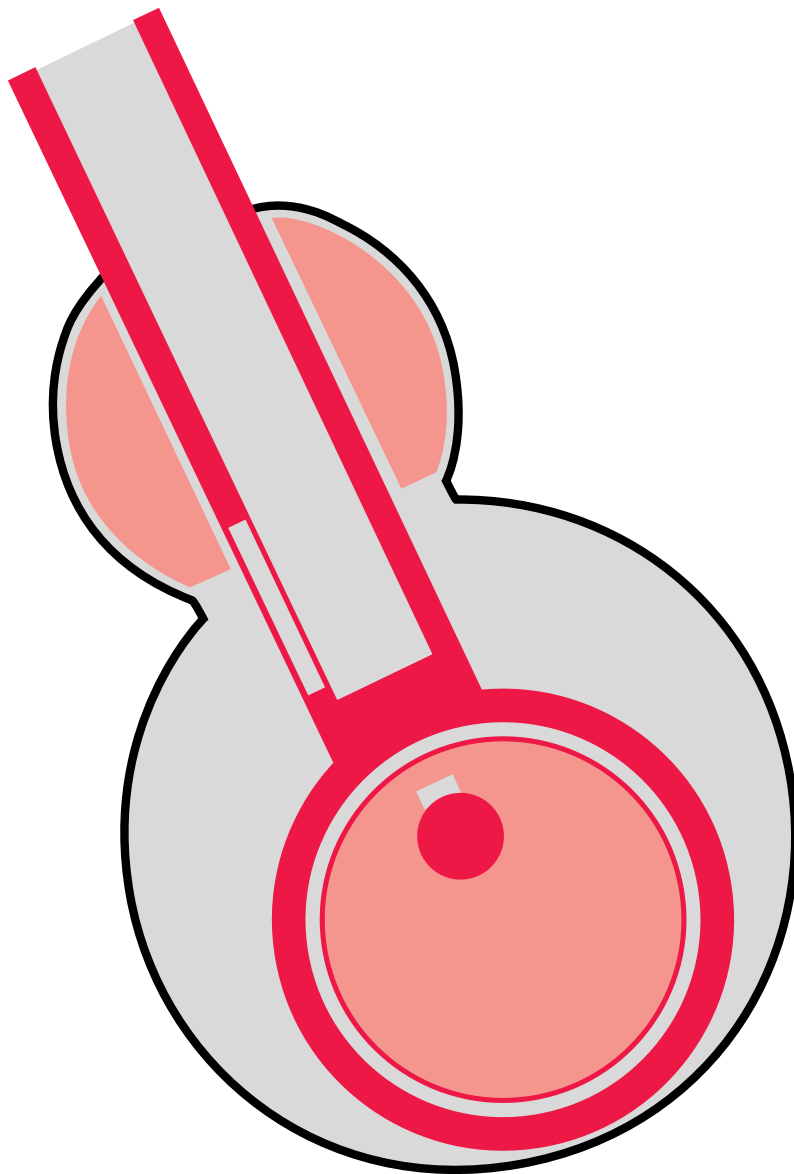

General

Applications and Operation	C06.03
Application and Accessories	C06.03

Products

Single-Stage Rotary Piston Vacuum Pump E 250	C06.04
Two-Stage Rotary Piston Vacuum Pump DK 200	C06.06

Accessories**Global Versions**

Valves	C06.08
Exhaust Filter Box AFK 2	C06.09
Oil Filter Unit	C06.10
Oil Control Unit	C06.10
Condensate Separator AK 100-250	C06.11
Exhaust Filter AF 100-250 A	C06.11
Dust Filter FS 100-250	C06.12
Dust Separator AS 100-250	C06.13

Versions for the North and South American Continents

Oil Filtering System OF1000	C06.14
Oil Filtering System OF3000	C06.16
Vibration Absorber	C06.17
Condensate Separator AK 100-250	C06.18
Exhaust Filter AF 100-250 A	C06.18

Miscellaneous

Vacuum Pump Oils	C06.19
60 Hz Curves	C06.22

Applications and Operation

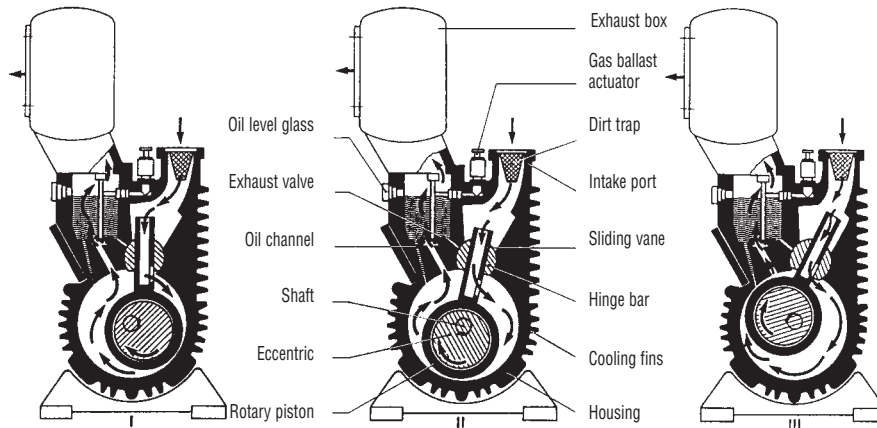

Functional diagram of a rotary piston vacuum pump

Advantages to the User

- ◆ Gas ballast facility
- ◆ Easy maintenance
- ◆ Good ultimate pressure with and without gas ballast
- ◆ High pumping speed at low intake pressures
- ◆ Compact design with flange mounted motor
- ◆ High water vapor tolerance
- ◆ Reliable continuous operation
- ◆ Tolerant and rugged, due to non-contact rotary piston within the pump chamber
- ◆ Very smooth operation due to dynamically balanced masses
- ◆ Separate oil filling for the gear protects the gear against contaminated pump oil
- ◆ Oil is used for sealing, lubrication and cooling
- ◆ A built-in anti-reverse lock prevents incorrect rotation of the piston and also stops it being pulled back when the pump is switched off while under vacuum

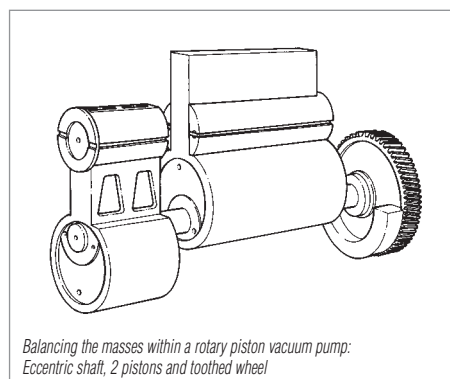

Balancing the masses within a rotary piston vacuum pump:
Eccentric shaft, 2 pistons and toothed wheel

- ◆ Air cooling makes the pump environmentally-friendly and economic
- ◆ Clear design and service-friendly due to the modular design

Technical Note

- ◆ By installing a filter, the oil may be cleaned simultaneously

Pumps		E 250	DK 200
Application			
Manufacture of semiconductors		◆	◆
Coating		◆	◆
Chemistry		◆	◆
Metallurgy		◆	◆
Electrical engineering		◆	◆
Mechanical engineering		◆	◆
Backing pump for a Roots vacuum pump in diffusion pump systems		◆	◆
Accessories			
	Page		
AFK Exhaust Filter Box	C06.09	◆	◆
Oil Filter Unit	C06.10	◆	◆
Oil Control Unit	C06.10	◆	◆
AK Condensate Separator	C06.11/18	◆	◆
AF Exhaust Filter	C06.11/18	◆	◆
FS Dust Filter	C06.12	◆	◆
AS Dust Separator	C06.13	◆	◆
Oil Filtering System OF1000	C06.14	◆	◆
Oil Filtering System OF3000	C06.16	◆	◆
Vibration Absorber	C06.17	◆	◆

Single-Stage Rotary Piston Vacuum Pump E 250

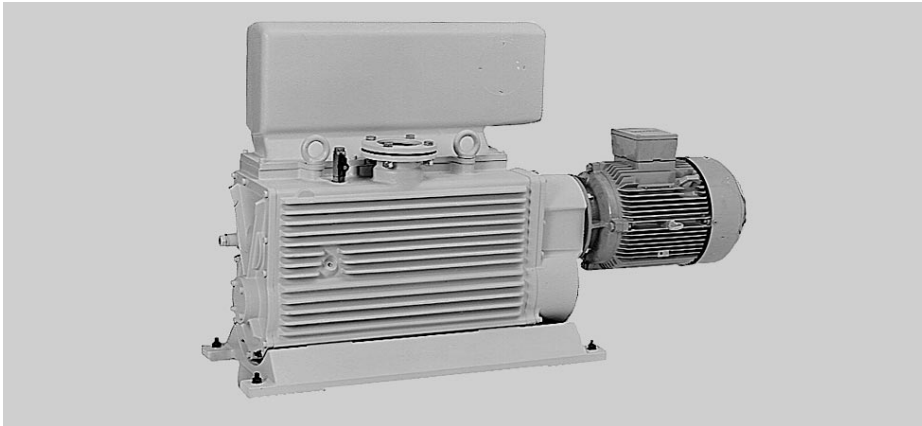

Typical Applications

- ◆ Chemical, metallurgical and electronic vacuum processes
- ◆ Impregnating, degassing and drying processes in experimentation systems, in drying cabinets, extrusion etc.
- ◆ Pressure range down to 4×10^{-2} mbar (2.4×10^{-2} Torr) without gas ballast or to 5×10^{-1} mbar (3×10^{-1} Torr) with gas ballast
- ◆ Backing pump for Roots vacuum pumps at intake pressure down to 10^{-3} mbar (0.75×10^{-3} Torr)

Supplied Equipment

- ◆ With DN 65 DIN flanges on the intake and exhaust sides for direct connection of DN 63 ISO-K flange components
- ◆ Ready for operation, complete with oil filling
- ◆ Special models for different motor voltages, motor frequencies and other protection class ratings are available. Details on these upon request.

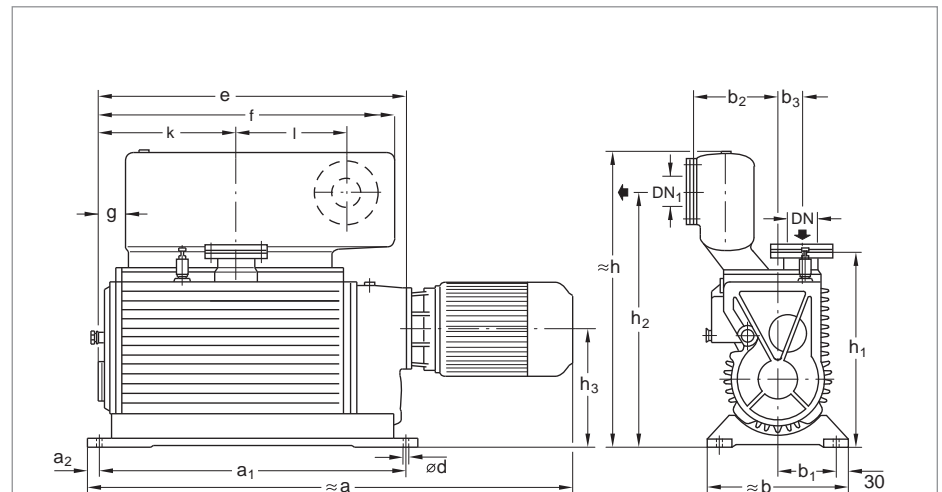
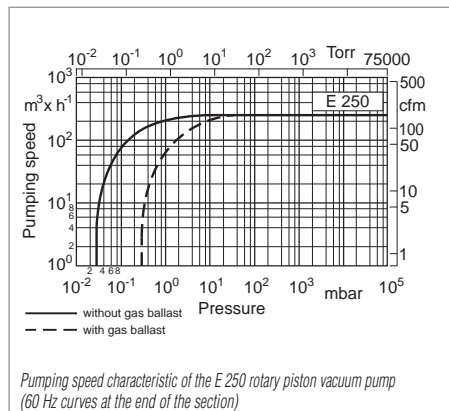
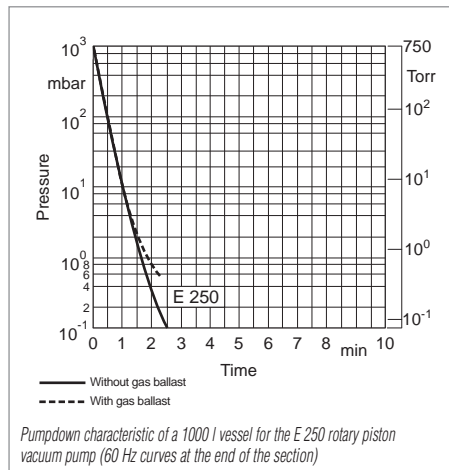

	DN	DN ₁	a ¹⁾	a ₁	a ₂	b	b ₁	b ₂	b ₃	ød	e	f	g	h	h ₁	h ₂	h ₃	k	l
mm	63 ISO-K	63 ISO-K	1190	780	30	340	140	202	52	14	777	750	65	740	475	636	295	337	290
in.	63 ISO-K	63 ISO-K	4.17	2.73	1.05	1.19	0.49	0.71	0.18	0.05	2.72	2.63	0.23	2.59	1.66	2.23	1.03	1.78	1.02

Pump flanges to DIN 2501 with sealing disc and collar flange for the connection of ISO-K (KF) components

¹⁾ Only for the motor which is supplied as standard

Dimensional drawing for the single-stage rotary piston vacuum pump E 250

Technical Data		E 250	
		50 Hz	60 Hz
Nominal pumping speed ¹⁾	m ³ x h ⁻¹ (cfm)	290 (170.8)	
Pumping speed ¹⁾	m ³ x h ⁻¹ (cfm)	250 (147.3)	
Ultimate partial pressure without gas ballast ¹⁾	mbar (Torr)	< 4x 10 ⁻² (< 2.4 x 10 ⁻²)	
Water vapour tolerance ¹⁾	mbar (Torr)	60 (45)	
Average noise level to DIN 45 635 ²⁾	dB(A)	< 76	
Mains voltage 3-ph.	V	230/400	208-230/460
Motor power at			
220 / 380 V, 50 Hz	kW (hp)	5.5 (7.5)	
220-230 / 460 V, 50 Hz	kW (hp)	5.5 (7.5)	
200-230 V / 460 V, 60 Hz	kW (hp)	5.5 (7.5)	
Nominal motor speed	rpm	1500	1800
Speed of the pump	rpm	540	
Motor protection	IP	54	
Oil filling	l (qt)	8.4 (8.9)	
Weight	kg (lbs)	375 (827)	
Intake port	DN	63 ISO-K	
Exhaust port	DN	63 ISO-K	

Ordering Information		E 250
Single-stage rotary piston vacuum pump		
E 250, with 50 Hz-motor ³⁾	(220 / 380 V +/- 10%)	Part No. 105 36
E 250, with 460 V/50 Hz motor ³⁾	(220-230 V / 460 V +/- 10%)	Part No. 895 08
E 250, with 460 V/60 Hz motor ^{3), *)}	(200-230 V / 460 V +/- 10%) USA version	Part No. 895 09
E 250, without motor, with 50 Hz gear ^{3) 4)}		Part No. 166 37
Sealing kit, pump		Part No. 192 63
Vibration absorbing metal feet		Part No. 101 55
SECUVAC valve		
200-230 V, 50/60 Hz		Part No. 215 207
115 V, 50/60 Hz		Part No. 215 206
ANSI adaptor		upon request

¹⁾ To DIN 28 400 and following numbers

²⁾ Operated at ultimate pressure without gas ballast, free field measurement at a distance of 1 m (3.5 ft). When fitting accessories, for example AFK2, the noise level may change by 2 to 3 dB(A)

³⁾ For operation at a different frequency, the gear will have to be exchanged. Please state the main frequency and connection (star or delta) in your order

⁴⁾ The maximum speed must not exceed 1,500 rpm at 50 Hz. The motor rating must be at least 5 kW (6.8 hp)

*) Continuous operation from 60 mbar (45 Torr)

Two-stage Rotary Piston Vacuum Pump DK 200

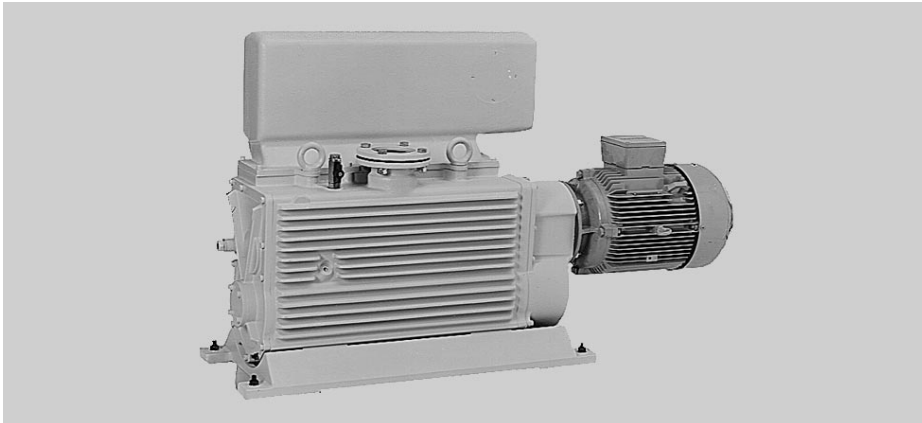

Typical Applications

- ◆ For particularly low ultimate pressures
- ◆ High vacuum stage with degassed oil from a separate oil reservoir
- ◆ For all chemical, metallurgical and electronic vacuum processes in the pressure range down to 5×10^{-4} mbar (3×10^{-4} Torr) without gas ballast and 4×10^{-3} mbar (2.4×10^{-3} Torr) with gas ballast
- ◆ Backing pump for Roots vacuum pumps
- ◆ Use as backing pump in pump systems in connection with diffusion, booster-type diffusion and vapor pumps

Supplied Equipment

- ◆ With DN 65 DIN flanges on the intake and exhaust sides for direct connection of DN 63 ISO-K flange components
- ◆ Ready for operation, complete with oil filling
- ◆ Special models for different motor voltages, motor frequencies and other protection class ratings available

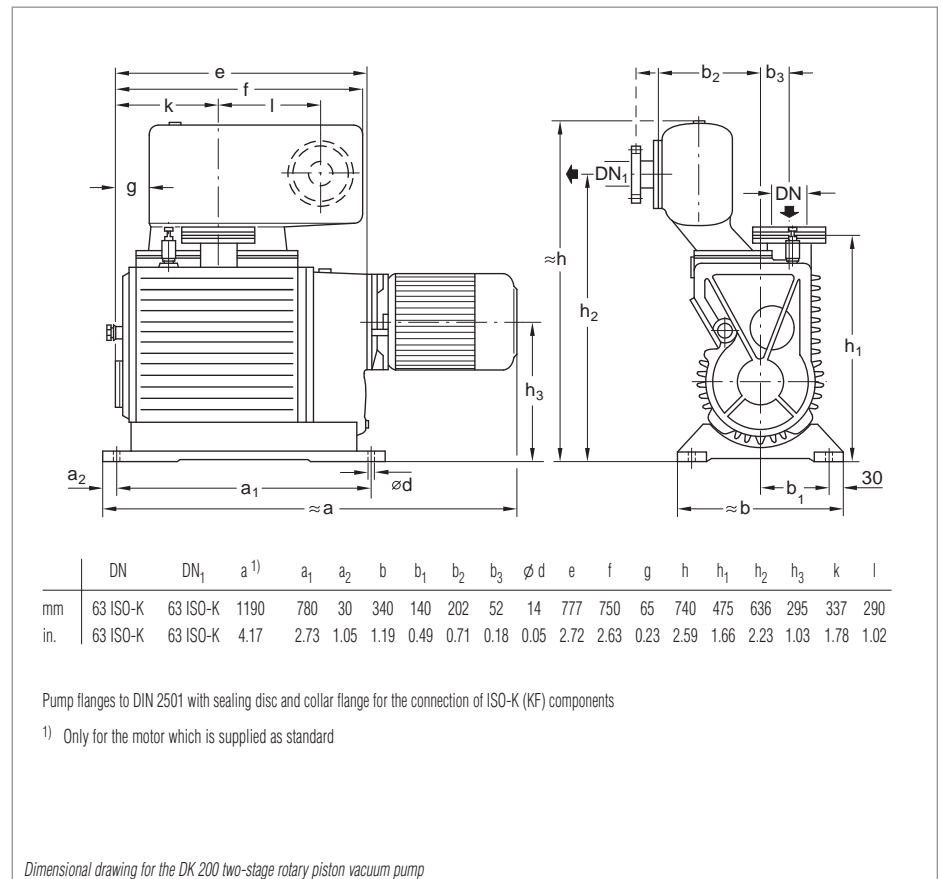
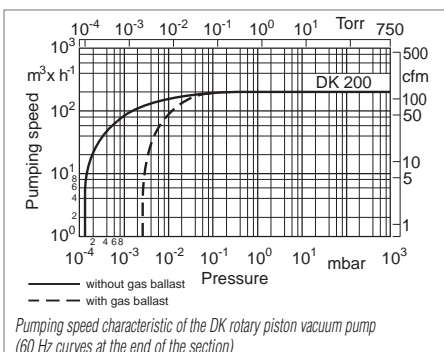
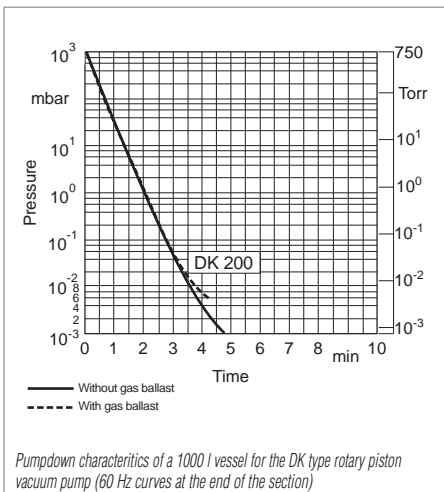

Technical Data		DK 200	
		50 Hz	60 Hz
Nominal pumping speed ¹⁾	m ³ x h ⁻¹ (cfm)	225 (132.5)	
Pumping speed ¹⁾	m ³ x h ⁻¹ (cfm)	200 (117.8)	
Ultimate partial pressure without gas ballast ¹⁾	mbar (Torr)	< 5 x 10 ⁻⁴ (< 3 x 10 ⁻⁴)	
Water vapour tolerance ¹⁾	mbar (Torr)	26 (19.5)	
Average noise level to DIN 45 635 ²⁾	dB(A)	< 76	
Main voltage	V	230/400/3/50	208-230/460/3/60
Motor power at			
220 / 380 V, 50 Hz	kW (hp)	5.5 (7.5)	
200-230 V / 380 V, 60 Hz	kW (hp)	5.5 (7.5)	
Nominal motor speed	rpm	1500	1800
Speed of the pump	rpm	540	
Motor protection	IP	54	
Oil filling	l (qt)	4.4 (4.6)	
Weight	kg (lbs)	375 (827)	
Intake port	DN	63 ISO-K	
Exhaust port	DN	63 ISO-K	

Ordering Information

DK 200

Two-stage rotary piston vacuum pump
 DK 200, with 50 Hz motor ³⁾
 (220 / 380 V +/- 10%)
 DK 200, with 60 Hz motor ³⁾, ^{*)}
 (200-230 V / 460 V +/- 10%) USA version
 DK 200, without motor, 50 Hz gear ³⁾ ⁴⁾

Part No. 111 16

Part No. 895 10

Part No. 166 17

Sealing kit, pump

Part No. 192 63

Vibration absorbing metal feet

Part No. 101 55

SECUVAC valve

Part No. 105 62

ANSI adaptor

upon request

¹⁾ To DIN 28 400 and following numbers

²⁾ Operated at ultimate pressure without gas ballast, free field measurement at a distance of 1 m (3.5 ft). When fitting accessories, for example AFK2, the noise level may change by 2 to 3 dB(A)

³⁾ For operation at a different frequency, the gear will have to be exchanged. Please state the main frequency in your order

⁴⁾ The maximum speed must not exceed 1,500 rpm at 50 Hz. The motor rating must be at least 5 kW (6.8 hp)

^{*)} Continuous operation from 30 mbar (22.5 Torr)

Valves

The flange components which are required for installation of the accessories to the pump must be ordered separately. For flange components and valves please refer to the corresponding Product Sections C13 and C14.

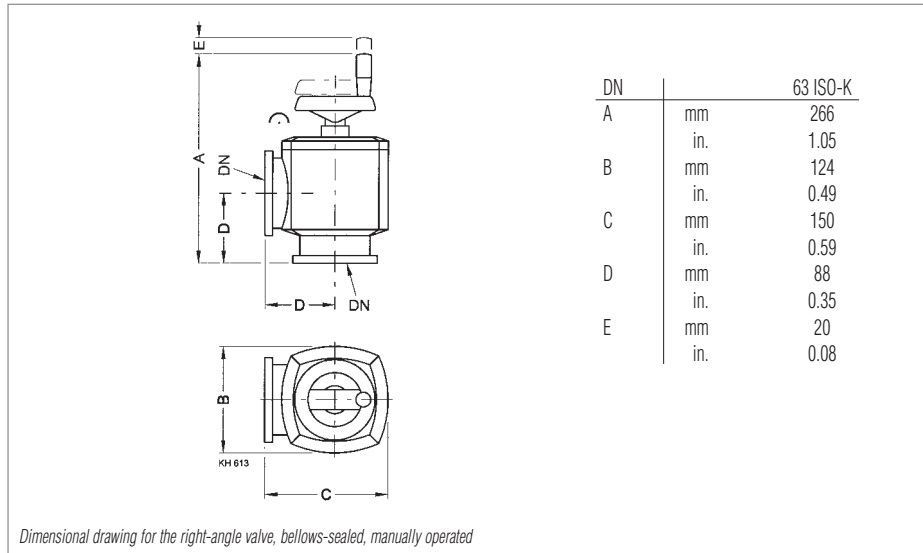

Advantages to the User

- ◆ The pump may warm up while the intake line is isolated
- ◆ Energy-conserving and environmentally-friendly operation at ultimate pressure
- ◆ The pump may continue to operate while the vacuum chamber is vented for brief periods
- ◆ After completion of a process the pump may continue to operate so as to regenerate the oil

Ordering Information

Right angle valve DN 63 ISO-K, AI, manually operated

Right Angle Valve

Part No. 107 80

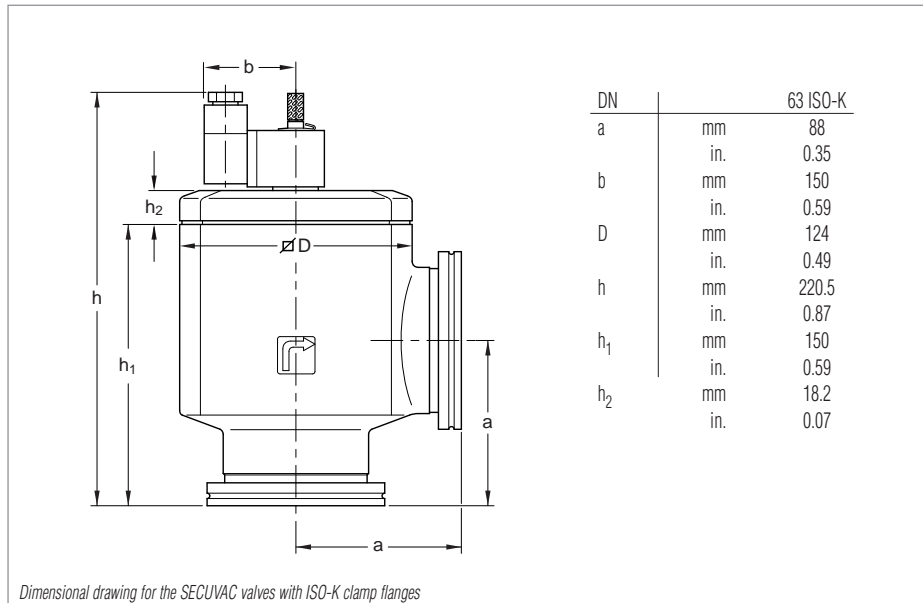

Advantages to the User

Two valve functions in one:

- ◆ Fast-closing high vacuum isolation valve for separating the vacuum chamber or a vapor jet pump (a diffusion pump, for example) from the backing pump
- ◆ Venting valve for venting of the valve's chamber and thus the pump (backing pump)
- ◆ Immediate closing action upon power failure
- ◆ Opening action only after the intake line has been evacuated
- ◆ Delayed isolation of the vacuum chamber and venting the vacuum pump (negligible "gulp")

Ordering Information

SECUVAC valve DN 63 ISO-K
 24 V DC
 100 - 115 V AC
 200 - 230 V AC

SECUVAC Valve

Part No. 215 205
 Part No. 215 206
 Part No. 215 207

Exhaust Filter Box AFK 2

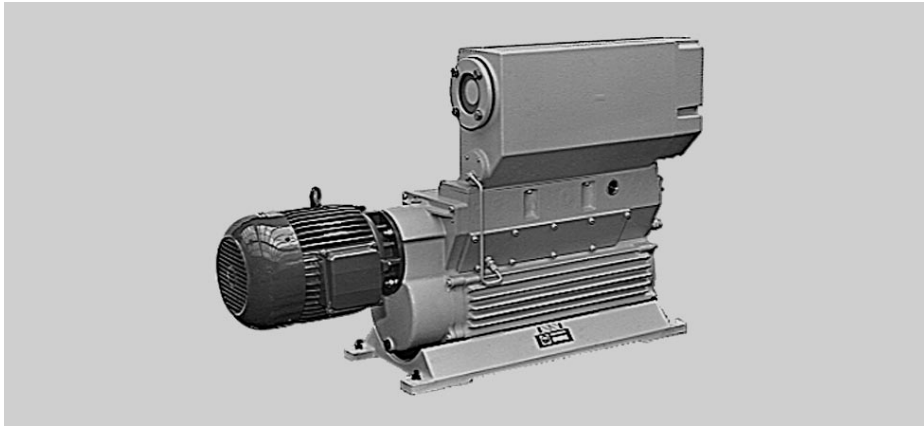

The oil mists entrained in the exhaust gas from the pump are cleaned in the exhaust filter box. The exhaust filter box is installed instead of the standard filter box on the rotary piston vacuum pump.

Advantages to the User

- ◆ At intake pressures below 100 mbar (75 Torr) this is a space saving alternative to the separate exhaust filter
- ◆ Almost oil-free exhaust gas, over 99 % effective
- ◆ Exchangeable filter elements
- ◆ Built-in overpressure valves
- ◆ Low oil consumption due to the integrated oil return line

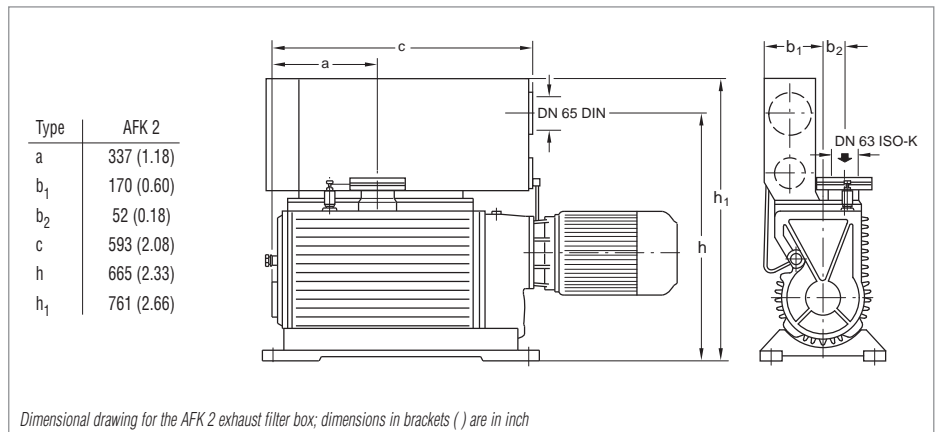

Technical Notes

In case of toxic or hazardous gases and vapors the exhaust lines must comply with the safety regulations.

Technical Data		AFK 2
Weight	kg (lbs)	10 (22.1)
Connection for collar flange	DN	63 ISO-K
Ordering Information		AFK 2
AFK 2 exhaust filter box, for E 250, DK 200		Part No. 189 47
Replacement filter element (FE) (2 are required)		Part No. 189 85

Oil Filter Unit



Mechanical oil filters are required when a severe contamination of the pump's oil can be expected due to solid particles like dust, for example.

Advantages to the User

- ♦ Protection of the pump against contamination of its oil
- ♦ Longer service life for the oil
- ♦ Easy to fit without having to disassemble the pump

Mechanical Oil Filter Unit

- ♦ Automatic oil circulation from the oil reservoir on the exhaust side via the filter to the intake chamber
- ♦ Filter insert which is easy to exchange (bypass filter)
- ♦ Particulate retention to 3 microns

Technical Notes

Increases the required quantity of oil by about 1.3 liters (1.34 qt).

When using the oil filter, the pump must be vented when shut down in order to prevent the oil from rising into the intake line; for this we suggest you install a SECUVAC valve.

Ordering Information

Mechanical oil filter unit with special filter insert, complete with adaptor screw and mount for attachment to the pump

Oil Filter Unit

Part No. 101 31

Replacement filter

Part No. 101 32

Ordering Information

Oil control unit

Oil Control Unit

Part No. 101 37

Replacement filter

Part No. 101 32

Oil Control Unit

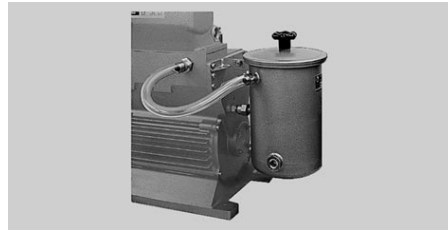

Adding the oil can be automated through the oil control unit without having to interrupt operation. For this purpose, an additional oil reservoir holding 7 liters (7.4 qt) is connected to the pump.

Advantages to the User

- ♦ Optimum oil level over long periods of operation
- ♦ Reduction of oil losses
- ♦ Visual function check (transparent connecting hose)
- ♦ Simple installation of the unit without the need to disassemble the pump
- ♦ Closed circuit by connection of oil reservoir, vessel and pump
- ♦ Built-in filter insert separates mechanical contamination

Technical Notes

You must under all circumstances use a SECUVAC valve, otherwise the oil reservoir will be emptied by the pump as soon as it is switched off.

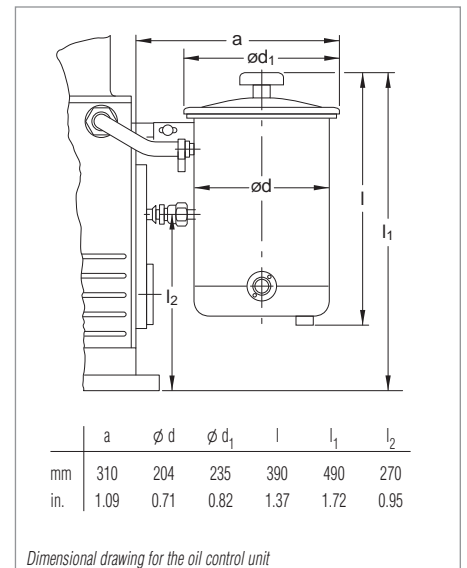
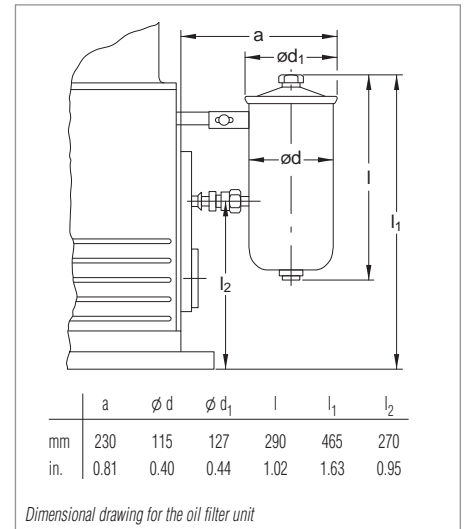

AK 100-250 Condensate Separator



Welded condensate collecting vessels.

Advantages to the User

- ◆ May be used either on the intake or the exhaust side
- ◆ Corrosion-protected
- ◆ Condensate level glass
- ◆ Protects the pump against condensate which collects in the exhaust line and the intake line
- ◆ Effect independent of the direction of flow

Technical Notes

When used on the intake side the drain cock must provide a vacuum-tight seal.

Half of the quantity of required clamping screws is provided.

AF 100-250 A Exhaust Filter



To remove oil mists entrained in the exhaust gas.

Advantages to the User

- ◆ Over 99% effective
- ◆ Optimally matched to our rotary piston vacuum pumps
- ◆ Exchangeable filter insert
- ◆ Built-in overpressure valves
- ◆ Sight glass for checking the amount of separated oil
- ◆ Solvent-resistant, helium-tight
- ◆ Cast aluminium housing
- ◆ Oil return (optional)

Technical Notes

In case of toxic or hazardous gases and vapors the exhaust lines must comply with the safety regulations.

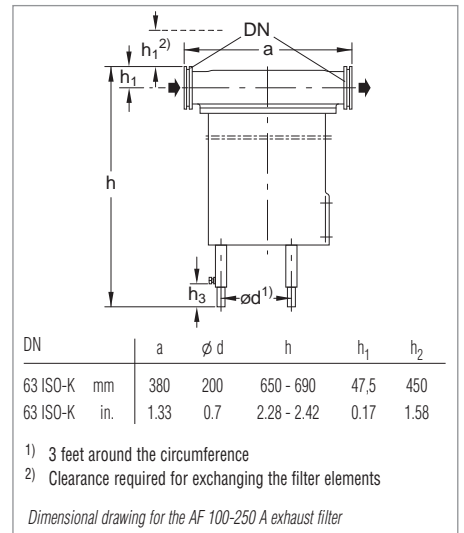
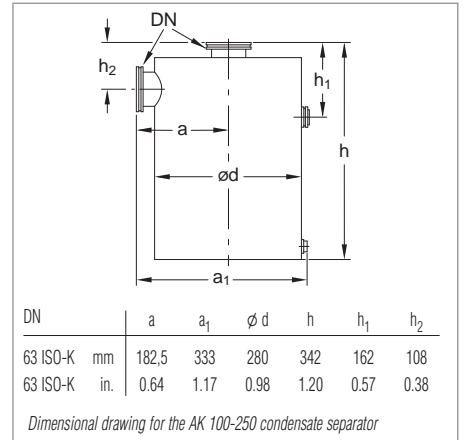

Technical Data		AK 100-250
Capacity for condensate	l (qt)	10 (9.46)
Weight	kg (lbs)	12 (26.5)
Connection	DN	63 ISO-K
Ordering Information		AK 100-250
AK 100-250 condensate separator		Part No. 188 45
Drain cock, vacuum-tight		Part No. 190 90
Connection components		
Connection to the intake side of the E 250, DK 200		
Elbow		Part No. 887 25
Centering ring		Part No. 268 07

Technical Data		AF 100-250 A
Weight	kg (lbs)	12 (26.5)
Connection	DN	63 ISO-K
Ordering Information		AF 100-250 A
AF 100-250 A exhaust filter		Part No. 189 45
Replacement filter element (2 are required)		Part No. 189 85
Drain cock, vacuum-tight		Part No. 190 90
Connection components		
Connection to the E 250, DK 200		
Bellows		Part No. 887 70
Centering ring ISO-K		Part No. 268 07

FS 100-250 Dust Filter



Dust filters protect the pumps against the intake of dust.

Advantages to the User

- ◆ Easy to disassemble
- ◆ Vacuum-tight cast housing
- ◆ Replacement filters
- ◆ Separates dust from a grain size of 1 µm

Technical Notes

Install horizontally so that the filter insert may be removed from below.

In case of very large quantities of dust use a dust separator.

Only throttles the pumping speed significantly at very low intake pressures.

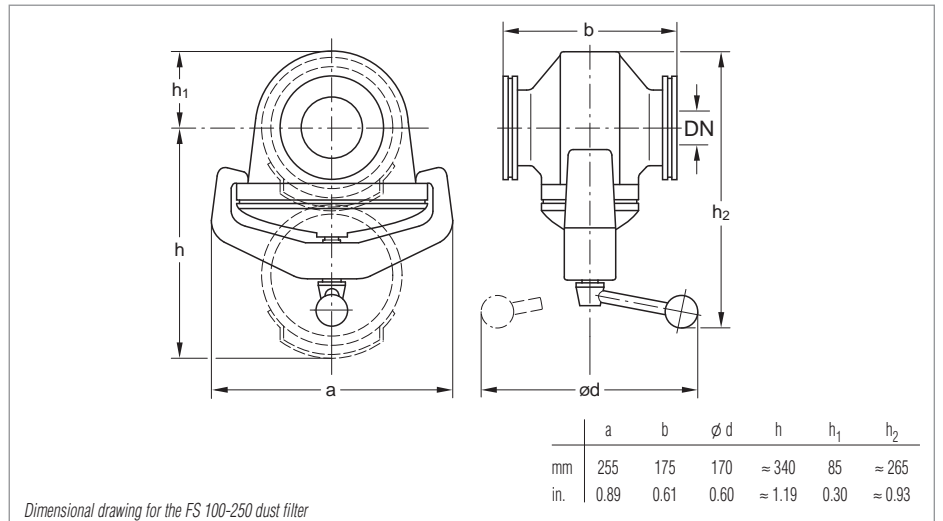

Supplied Equipment

Half of the quantity of required clamping screws is provided.

Technical Data		FS 100-250
Connection to pump		E 250, DK 200
Throttling of pumping speed		
at an intake pressure of 13 mbar (9.8 Torr) approx. %		28
at an intake pressure of 1.3 mbar (0.98 Torr) approx. %		38
Weight	kg (lbs)	11 (24.3)
Connection	DN	63 ISO-K

Ordering Information		FS 100-250
FS 100-250 dust filter		Part No. 278 17
Filter insert		Part No. 178 37
Replacement cotton wadding cartridges (1 set = 10 pieces)		Part No. 178 27
Connection components		
Connection to the E 250, DK 200		
Elbow		Part No. 887 25
Centering ring		Part No. 268 07
ANSI adaptor		upon request

AS 100-250 Dust Separator

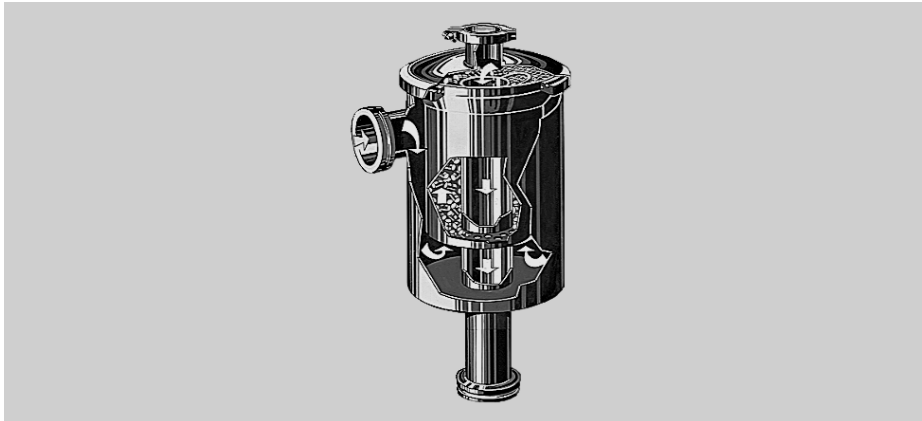

Dust separators protect the pumps against being contaminated by dust.

Advantages to the user

- ◆ Dust separator for large quantities of dust
- ◆ Dual-stage, thus low throttling effect
- ◆ Cyclone and wet filter
- ◆ Replacement inserts for both filters
- ◆ Dust of a grain size of 2 µm and more are separated in a cyclone
- ◆ Finer dust is separated in an insert moistened with oil

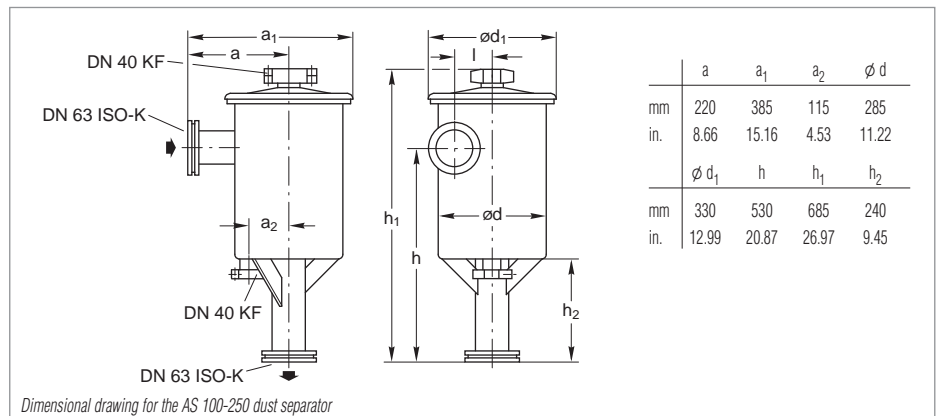

Technical Notes

Dust separator filters throttle the pumping speed only at low intake pressures.

Supplied Equipment

Half of the quantity of required clamping screws is provided.

Technical Data		AS 100-250
Connection to pump		E 250, DK 200
Throttling of pumping speed		
at an intake pressure of 13 mbar (9.8 Torr) approx. %		3.5
at an intake pressure of 1.3 (0.98 Torr) mbar approx. %		7
Capacity for dust	l	4.0
Weight	kg (lbs)	27 (59.5)
Connection	DN	63 ISO-K
Ordering Information		AS 100-250
AS 100-250 dust separator		Part No. 178 02
Filter insert		Part No. 178 06

Version for the North and South American Continents

OF1000 Oil Filtering System

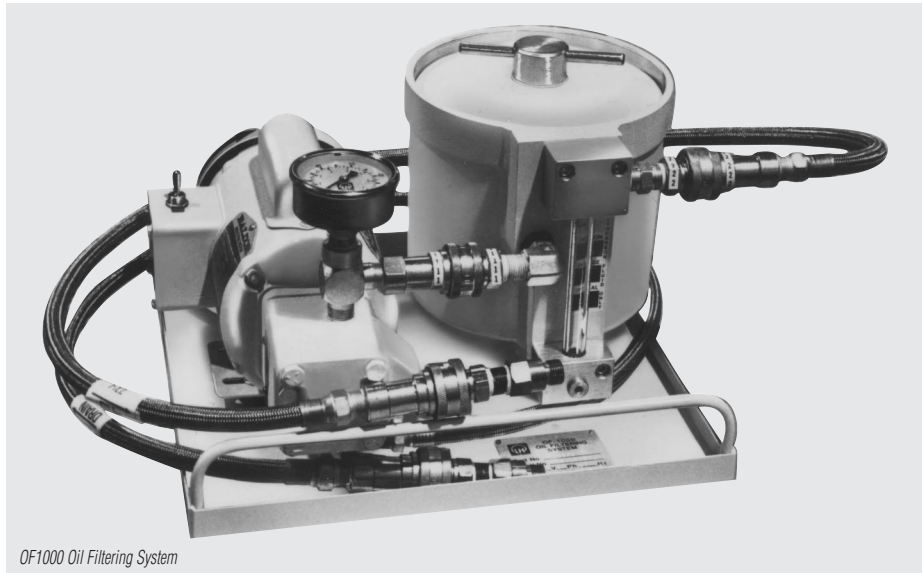

OF1000 Oil Filtering System

Advantages to the User

- ◆ Choice of Single- and Dual-Canister Models for Standard or Chemically Severe Applications
- ◆ Compact Design
- ◆ Reliable Operation
- ◆ Choice of Four Filtering Elements
- ◆ Dripless Quick Disconnects for Easy Removal and Replacement of Filter Elements
- ◆ Recessed Lid and Oil Level – No Oil Spillage
- ◆ Conductive Teflon Hoses for Static Charge Dissipation – No Oil Leakage Due to Static Burning
- ◆ Integral Gear Pump with Built-In Bypass
- ◆ Fluid Sight Glass and Flow Monitor
- ◆ Pressure Gauge
- ◆ Small Precharge Fluid Volume
- ◆ Single Phase 50/60 Hz Motors Standard

Applications

Standard series models are widely used in silicon production processes, including LPCVD, low-pressure epitaxy, ion implantation, reactive ion etching and several plasma processes. Such processes employ a variety of gases which can react with pump fluid, resulting in the formation of sludge, particulates and acids. The standard OF1000 model has proven effective at extending maintenance intervals in such applications.

Similarly, chemically resistant OF1000C models have proven successful in aluminum etching and other processes where boron trichloride and other highly toxic gases are employed. The canister, gear pump, fittings and quick disconnects of the corrosive-service model have been specially treated with a fluorocarbon material that substantially increases the life of these components.

OF 1000 Oil Filtering Systems are designed to remove acids and particulates from the lubricating fluid used in Leybold mechanical vacuum pumps. The systems are located externally from the vacuum pump, and utilize their own integral gear pump in conjunction with a bypass to continuously recycle fluid through a filtering medium; the medium is housed in an element/canister assembly which additionally serves to absorb heat, and thus reduce the operating temperature of the vacuum pump.

OF1000 Systems are available in both single- and dual-canister designs. Both types are highly compact and reliable, and can be supplied in models for standard or chemically severe applications.

Single-canister OF1000 models are distinguished by their smaller footprint while dual-canister configurations afford the advantages of multi-media filtration and increased oil capacity. Dual-canister models are designed for series flow through two side-by-side mounted canisters, and thus can be used to filter oil through two different media on the same pass or for double filtration through elements containing the same medium. The models also enable the vacuum pump to operate at somewhat lower temperatures, while providing it with a larger supply of clean, filtered oil.

All OF1000 models are supplied with a choice of four filtering elements. The Fullers Earth element provides high capacity for standard acids and can be used to trap particulates down to 10 micron in size. Hydrophilic, activated alumina and fiberglass particulate elements are also available. The hydrophilic element is particularly effective for hydrolyzed acids, and can also be used to trap particles as small as 1 micron. The activated alumina element provides 10 micron particulate retention and is extremely effective for Lewis acids and polar compounds. The fiberglass element is suitable for particulate removal down to 10 micron.

The element/canister assembly of OF1000 systems is easy to install, extremely easy to remove and replace. The recessed lid and oil level of the assembly safeguards against the possibility of spillage. Dripless quick disconnects are also provided for easy canister removal and safer disposal of the filtering element and oil.

OF1000 Systems also come equipped with flexible Teflon hoses designed to resist dielectric breakdown. The systems thus ward against the possibility of oil leaks due to pinholing or static burning of the hose.

Version for the North and South American Continents

Technical Data		Single-Canister Systems	Dual-Canister Systems
Gear Pump Motor		1/6 HP, 115/208/220V, single phase, 50/60Hz, wired for 115V, with on/off switch ¹⁾	
Gear Pump		0.7 gpm @ 1800 RPM	
Pressure Gauge		0 to 100 psig (0 to 70 kPa)	
Pump Fluid Capacity		15 lb perfluorinated polyether or 3.75 qt hydrocarbon oil	29 lb perfluorinated polyether or 7.25 qt hydrocarbon oil
Flexible Hoses		3/8 in. I.D. teflon/carbon black with stainless steel braid – 4 ft lengths ²⁾	
Dimensions	in. (mm)	16 x 14 x 11 (406 x 356 x 279)	23 x 14 x 11 (585 x 356 x 279)
Flow Arrangement		–	series ³⁾
Weight (Dry)	lbs	45	60
Ordering Information		Single-Canister Systems	Dual-Canister Systems
Oil Filtering System			
OF1000 Less Filtering Element and Oil		Part No. 898 550	Part No. 898 552
OF1000 Prepared for PFPE, Less Filtering Element and Oil		Part No. 898 551	Part No. 898 553
OF1000C Chemically Severe Service, Prepared for PFPE Fluid		Part No. 898 561	Part No. 898 554
Accessories			
Spare Filter Canister Assembly With Quick Disconnect Prepared for PFPE, With Quick Disconnect Chemically Severe Service		Part No. 898 555 Part No. 898 556 Part No. 898 566	Part No. 898 557 (front), Part No. 898 555 (rear) Part No. 898 558 (front), Part No. 898 556 (rear) Part No. 898 559 (front), Part No. 898 566 (rear)
Filtering Elements			
Aluminum Oxide — High Capacity for Reagent Grade HCl; Removes Lewis Acids and PolarCompounds; 10 Micron Particulate Retention		Part No. 898 504	Part No. 898 504
Fullers Earth — Acid and Particulate Filter with Capacity of 34 ml Reagent Grade HCl; 10 Micron Particulate Retention		Part No. 898 505	Part No. 898 505
Hydrophilic — Water and HCl Acid Absorbing Capabilities; 1 Micron Particulate Retention		Part No. 898 506	Part No. 898 506
Particulate — Fiberglass Element with 10 Micron Particulate Retention		Part No. 898 507	Part No. 898 507

¹⁾ Hazardous duty models and special voltages also available

²⁾ Optional 6, 10 and 15 feet hoses available

³⁾ Optional parallel flow arrangement also available

Version for the North and South American Continents

OF3000 Oil Filtering System



The OF3000 is a compact, highly mobile filtering system designed for use with mechanical pumps in applications generating large volumes of heavy particulate filtration.

A positive feed gear pump and check valve assembly protect against excessive backpressure in the canister should the filter element become clogged. Flexible hoses and matched dripless connectors ensure easy maneuverability of the OF3000's rollaround cart, while also eliminating the possibility of oil spills.

Operation

Contaminated oil is removed from the drain location on the vacuum pump and is cycled to the element assembly. Clean oil is subsequently circulated back to the oil fill port of the vacuum pump.

The tangential flow inlet port to the oil filter canister allows full oil flow while utilizing the entire filter capability of the element. This translates into longer filter life, fewer element changes, and less oil loss.

Similarly, chemically severe OF3000 models have proven successful in aluminum etching and other processes where boron trichloride and other highly toxic gases are employed. The canister, gear pump, fittings and quick disconnects of the corrosive-service model have been specially treated with a fluorocarbon material that substantially increases the life of these components.

Advantages to the User

- ◆ Compact, mobile design
- ◆ Choice of five filter elements
- ◆ Dripless quick disconnects for easy removal and replacement of filter elements
- ◆ No spillage - recessed lid and oil level
- ◆ Conductive teflon hoses for static charge dissipation
- ◆ Integral gear pump with built-in bypass
- ◆ Pressure gauge
- ◆ Oil sight glass
- ◆ Single phase 50/60 Hz motor standard
- ◆ Tangential flow inlets - improves oil flow
- ◆ Canister drain valve

Filtering Elements

Fullers Earth - Provides high capacity for standard acids and can be used to trap particulates down to 10 micron size.

Hydrophylic - Effective for hydrolyzed acids and particulates as low as one micron.

Activated Alumina - Effective on Lewis acids and polar compounds. Can be used to trap particulates down to 10 microns.

Particulate (Paper) - Suitable for particulate removal down to 10 microns.

Particulate (Fiberglass) - Suitable for particulate removal down to 10 microns.

Version for the North and South American Continents

Technical Data		OF3000	Ordering Information	OF3000
Gear pump motor		1/6 HP, 115/208/220 V, single phase, 50/60 Hz, wired for 115 V, with on/off switch	OF3000, less element and oil (standard)	Part No. 898 625
Gear pump		0.7 gpm @ 1800 rpm	OF3000C, coated, prepared for PFPE	Part No. 898 450
Pressure gauge		0 to 100 psig (0 to 70 kPa)	OF3000, prepared for PFPE	Part No. 898 455
Fluid capacity (approx.)	gal	3	Accessories	
Flexible hoses	in. I.D.	78 teflon/carbon black with stainless steel braid - 6 ft lengths	Aluminum oxide	Part No. 898 523
Dimensions	in. (mm)	18 x 14 x 26 (457 x 355 x 661)	Hydrophilic	Part No. 898 525
Weight (dry)	lbs (kg)	65 (29.4)	Fullers earth	Part No. 99 171 159
			Particulate (paper)	Part No. 898 599
			Particulate (fiberglass)	Part No. 99 171 158

Vibration Absorber

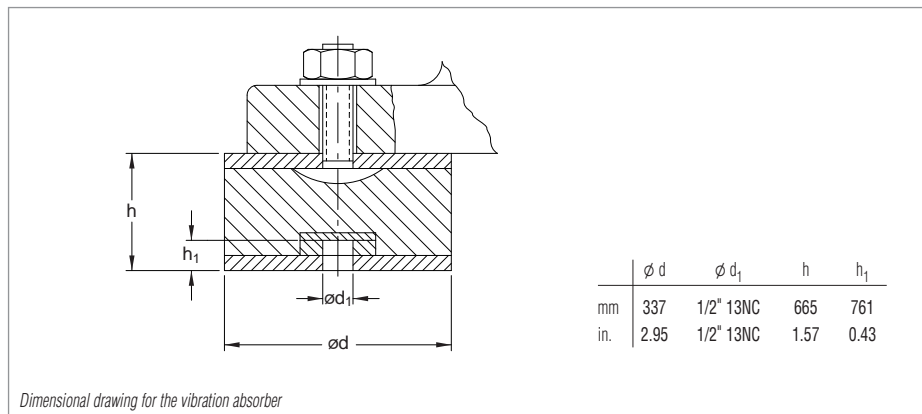

E and DK series rotary piston mechanical pumps are dynamically balanced for vibration-free performance in normal. In applications where pumps must be installed on light frames or wooden flooring, however, excess vibration can result from the lack of solid support.

Advantages to the User

- ◆ Reduce transmitted vibration by 60%
- ◆ Rubber vibration-absorbent varies in hardness for pumps of different weights
- ◆ Tapped holes provided in absorbers for attaching to frame or floor
- ◆ Shipped complete with all necessary mounting hardware

Ordering Information	Vibration Absorber
Vibration absorber (set of 4) (for E 250, DK 200)	Part No. 101 55-1

Version for the North and South American Continents

AK 100-250 Condensate Separator



Welded condensate collecting vessels.

Advantages to the User

- ◆ May be used either on the intake or the exhaust side
- ◆ Corrosion-protected
- ◆ Condensate level glass
- ◆ Protects the pump against condensate which collects in the exhaust line and the intake line
- ◆ Effect independent of the direction of flow

Technical Notes

When used on the intake side the drain cock must provide a vacuum-tight seal.

Half of the quantity of required clamping screws is provided.

AF 100-250 A Exhaust Filter



To remove oil mists entrained in the exhaust gas.

Advantages to the User

- ◆ Over 99% effective
- ◆ Optimally matched to our rotary piston vacuum pumps
- ◆ Exchangeable filter insert
- ◆ Built-in overpressure valves
- ◆ Sight glass for checking the amount of separated oil
- ◆ Solvent-resistant, helium-tight
- ◆ Cast aluminium housing
- ◆ Oil return (optional)

Technical Notes

In case of toxic or hazardous gases and vapors the exhaust lines must comply with the safety regulations.

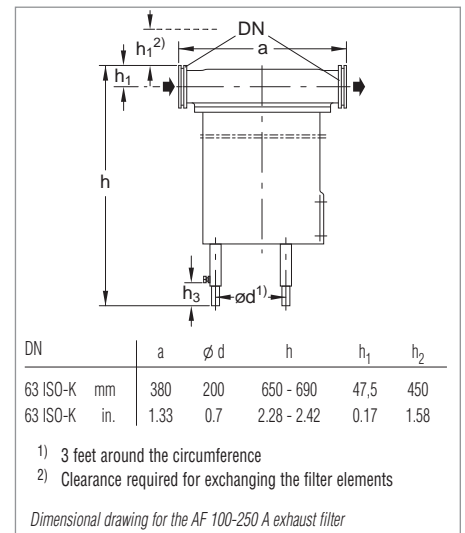
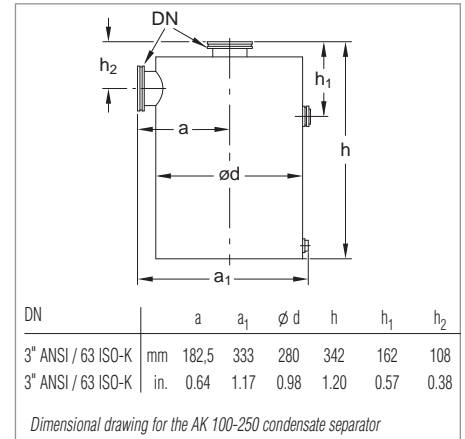

Technical Data		AK 100-250
Capacity for condensate	l (qt)	10 (9.46)
Weight	kg (lbs)	12 (26.5)
Connection	DN	63 ISO-K
Ordering Information		AK 100-250
AK 100-250 condensate separator, DN 63 ISO-K		Part No. 188 45
AK 100-250 condensate separator, ASA		Part No. 188 45-M
Vacuum-tight draining tap (pump inlet)		Part No. 190 90
Inlet position (E 150, E 250, DK 100, DK 200)		
3" elbow (1 is required)		Part No. 98-278-0347
3" ANSI rotatable flanges (2 are required)		Part No. 98-278-0700
3" ANSI seal disc (2 are required)		Part No. 910-181-605
Exhaust position (E 250, DK 200)		
3" ANSI seal disc (2 are required)		Part No. 910-181-605

Technical Data		AF 100-250 A
Weight	kg (lbs)	12 (26.5)
Connection	DN	63 ISO-K
Ordering Information		AF 100-250 A
AF 100-250 A exhaust filter, DN 63 ISO-K		Part No. 189 45
AF 100-250 A exhaust filter, ASA		Part No. 189 45-M
Kit includes		
Exhaust filter		Part No. 189 45
ANSI bellows		Part No. 991-051-013
ANSI sealing disc (2 are required)		Part No. 910-181-605
ANSI rotatable flange		Part No. 982-780-700
Spare filter elements for E 250, DK 200 (2 are required)		Part No. 390-261-44
Drain tap		Part No. 188 90
Note: Fittings will adapt filter only to exhaust port of pump. Kit does not include fittings to adapt exit port of filter. Please refer to section C13 "Vacuum Fittings" for additional options		

Vacuum Pump Oils

Lubricating oils for rotary vacuum pumps need to fulfil demanding requirements. Their vapor pressure must be low also at high temperatures, water content and water uptake must be minimal. Their viscosity characteristics need to be flat, lubricating properties need to be excellent and they must resist cracking upon being mechanically stressed.

All the vacuum pump oils listed in the following have been subjected in our factory laboratories to very comprehensive tests closely resembling the conditions encountered in practice by the pumps from the E + DK series.

We therefore recommend the exclusive use of vacuum pump oils fully qualified by Leybold so as to ensure optimum performance of the Leybold vacuum pumps and also to ensure optimum oil change intervals.

Under vacuum conditions lubricating oils, especially those with additives may behave quite differently than expected. Additives may adversely affect the attainable ultimate pressure and may react with the media being pumped.

When using not suitably qualified third party oils, the oil change intervals and the performance of the vacuum pump may be reduced. Also unwanted deposits may occur which may even cause severe damage to the vacuum pump. For these reasons please understand that we must make our warranty commitment dependent on the use of oils which have been qualified by us. Damages caused by the use of not suitably qualified lubricating oils are not covered by our warranty.

In order to adapt the pumps to the different applications of our customers, different types of oil are used in the E + DK pumps.

Please note that owing to differing properties not all types of oil may be used in all pumps of the E + DK series. If you can not find the combination of pump and oil you require please ask us for a quotation.

Lubricant Types

Mineral Oils

Mineral oils are products distilled and refined from crude oil. These do not consist of precisely defined compounds but rather consist of a complex mixture. The way in which the mineral oil is pre-treated and its composition are decisive as to the applications it will be suited for. Depending on the distribution of the hydrocarbons and the dominance of certain properties, mineral oils are grouped according to paraffin-base, naphthenic and aromatic. For the purpose of attaining especially low ultimate pressures, mineral oils must be selected on the basis of a core fraction.

The thermal and chemical resistance of mineral oils has been found to be adequate in the majority of applications. They offer a high degree of compatibility with elastomers and resistance to hydrolysis.

Perfluorinated polyether (PFPE)

These are oils which are only composed of carbon (C), fluorine (F) and oxygen atoms (O). The existing C-O and C-F bonds are highly stable. For this reason PFPE oils are practically inert against all chemical and oxidising influences.

Perfluorinated polyether will not polymerise under the influence of high energy radiation.

For all lubricants from our line of products you may obtain Safety Data Sheets from the Dept. Technical Support in Cologne.

PFPE is non-flammable. Leybold NC1/14 has the approval of BAM (Federal Institute for Materials Research and Testing) for pumping of pure oxygen.

Perfluorinated polyether are used when pumping strongly reactive substances like oxygen (O₂), fluorine F₂ and uranium hexafluoride UF₆. Regarding Lewis acids (for example, boron trifluoride BF₃, aluminum trichloride AlCl₃) they are not completely inert. Here reactions may take place at temperatures over 100 °C (212 °F).

Perfluorinated polyether are thermally highly stable. Thermal decomposition may only take place at temperatures of over 290 °C (554 °F).

Caution: Perfluorinated polyether will – when decomposed – release toxic and corrosive gases: hydrogen fluoride HF, carbonyl difluoride COF₂. For this reason open fires must be avoided in the workspace where PFPE is being used. Do not smoke in the workspace where PFPE is being used.

Only suitably prepared pumps must be used in connection with perfluorinated polyether, since it is essential that the pumps be free of hydrocarbons.

Changing from one basic type of oil to PFPE must be left exclusively to authorised Service Centers. The pump will have to be fully disassembled and carefully cleaned. Gaskets and filters will have to be exchanged and suitable greases will have to be used.



Application Data	Special Oil N62	NC 1/14
Type of oil	Paraffin-base mineral oil, core faction, free of additives	Perfluorinated polyether PFPE
Examples of areas of application and process media	Standard oil For pumping air, chemically inert permanent gases (noble gases, for example), water vapor, solvent vapors in the case of laboratory pumps operated with cold traps	For pumping strong oxidants like oxygen, O ₂ , ozone O ₃ , nitrogen oxides NO _x and sulphur oxides (SO ₂ , SO ₃) as well as reactive substances like halogens (for example fluorine F ₂ , chlorine Cl ₂), hydrogen halides (for example hydrogen chloride HCl, hydrogen bromide HBr), uranium hexafluoride UF ₆ , and conditionally Lewis acids (for example boron trichloride BCl ₃) Use only in pumps modified for PTFE
Remarks	The ultimate pressures stated in our catalogs are based on operation of the pump with N62 (except for the PFPE pumps) Service life may be extended through the use of an oil filter	Avoid pumping water vapour, in particular in connection with corrosive media (see above) In ingress of water vapor must be avoided The use of an oil filter is strongly recommended
Elastomer compatibility		
FPM (Viton)	Suited	Suited
NBR (Perbunan) ¹⁾	Conditionally suited	Suited
EPDM	Not suited	Suited

Technical Data	Special Oil N62	NC 1/14
Viscosity		
at 40 °C (104 °F)	mm ² /s 90	47
at 100 °C (212 °F)	mm ² /s 10	5
Flash point	°C (°F) > 255 (> 491)	- ²⁾
Vapor pressure		
at 20 °C (68 °F)	mbar (Torr) < 1 x 10 ⁻⁵ (< 0.75 x 10 ⁻⁵)	3 x 10 ⁻⁷ (2.25 x 10 ⁻⁷)
at 100 °C (212 °F)	mbar (Torr) < 3 x 10 ⁻³ (< 2.25 x 10 ⁻³)	6 x 10 ⁻⁴ (4.5 x 10 ⁻⁴)
Density at 20 °C (68 °F)	g/ml 0.88	1.89
Pour point	°C (°F) < -9 (< -16)	-40 (40)
Middle molecular weight	g/mol 550	2500

Ordering Information	Special Oil N62	NC 1/14
1 litre (1.06 qt)	Part No. 177 01	Part No. 177 38
5 litres (5.29 qt)	Part No. 177 02	-
20 litres (21.14 qt)	Part No. 177 03	-
180 kg (397.4 lbs)	Part No. 177 05	-

Please note that the technical data stated are only typical data. Slight variations from batch to batch must be expected.

The technical data stated here can not be taken as assured properties

- 1) Resistance to decomposing is very much dependent on the share of acrylonitrile in the NBR
- 2) **Caution:** Perfluorinated polyether will, when being decomposed at temperatures over 290 °C (554 °F), release toxic and corrosive gases
For this reason open fires must be avoided in the workspace where PFPE is being used. Do not smoke in the workspace where PFPE is being used

Version for the North and South American Continents

Application Data	HE-200	HE-2700
Type of oil	Paraffin-base mineral oil, core fraction, free of additives	Perfluorinated polyether PFPE
Examples of areas of application and process media	Standard oil for Leybold USA For pumping air, chemically inert permanent gases (noble gases, for example), water vapor, solvent vapors in the case of laboratory pumps operated with cold traps	For pumping strong oxidants like oxygen, O ₂ , ozone O ₃ , nitrogen oxides NO _x and sulphur oxides (SO ₂ , SO ₃) as well as reactive substances like halogens (for example fluorine F ₂ , chlorine Cl ₂), hydrogen halides (for example hydrogen chloride HCl, hydrogen bromide HBr), uranium hexafluoride UF ₆ , and conditionally Lewis acids (for example, boron trichloride BCl ₃)
Remarks	The ultimate pressures stated in our catalogs are based on operation of the pump with HE-200 (except for the DOT and PFPE pumps) Service life may be extended through the use of an oil filter.	Use only correspondingly modified pumps Mixing with other types of oil must be absolutely avoided The uptake of water vapor must be avoided The use of an oil filter is strongly recommended
Elastomer compatibility FPM (Viton) NBR (Perbunan) ¹⁾ EPDM	Suited Conditionally suited Not suited	Suited Suited Suited

Technical Data	HE-200	HE-2700
Viscosity		
at 20 °C (68 °F) mm ² /s (= cSt)	–	250
at 40 °C (104 °F) mm ² /s (= cSt)	58	–
at 100 °C (212 °F) mm ² /s (= cSt)	9.1	10
Flash point °C (°F)	224 (435)	Not known ²⁾
Vapor pressure		
at 20 °C (68 °F) mbar (Torr)	–	6.7 x 10 ⁻⁷ (5 x 10 ⁻⁷)
at 25 °C (77 °F) mbar (Torr)	4.7 x 10 ⁻⁶ (3.5 x 10 ⁻⁶)	–
at 100 °C (212 °F) mbar (Torr)	3.9 x 10 ⁻⁴ (2.9 x 10 ⁻⁴)	6.7 x 10 ⁻⁵ (5 x 10 ⁻⁵)
Density at 20 °C (68 °F) g/ml	0.88	1.89
Pour point °C (°F)	- 10 (14)	- 34 (- 30)
Molecular weight	480	4600

Ordering Information	HE-200	HE-2700
1 qt (1 l)	Part No. 98 198 006	–
1 gal (3.8 l)	Part No. 98 198 007	–
5 gal (18.9 l)	Part No. 98 198 008	–
55 gal (208 l)	Part No. 98 198 010	–
Bottle 2 lb (0.91 kg)	–	Part No. 898 565-1
Bottle 4 lb (1.81 kg)	–	Part No. 898 565-2
Bottle 16 lb (7.25 kg)	–	Part No. 898 565-4

Please note that the technical data stated are only typical data. Slight variations from batch to batch must be expected.

The technical data stated here can not be taken as assured properties

¹⁾ Resistance to decomposing is very much dependent on the share of acrylonitrile in the NBR

²⁾ **Caution:** Perfluorinated polyether will, when being decomposed at temperatures over 290 °C (554 °F), release toxic and corrosive gases

For this reason open fires must be avoided in the workspace where PFPE is being used. Do not smoke in the workspace where PFPE is being used

Version for the North and South American Continents

