

# Vacuum Boosters

## Models 150, 240, 400

Bi-directional Rotation

Series Options:

Vertical Flow, Mechanical Seals

Horizontal Flow, Mechanical Seals

Vertical Flow, Slinger Seals

Horizontal Flow, Slinger Seals

Vacuum boosters are used to “supercharge” vacuum pumps to greatly extend pump performance. This allows for much faster pumping speeds and deeper vacuum levels. M-D Pneumatics vacuum boosters from Tuthill Vacuum & Blower Systems are utilized worldwide in the manufacture of chemicals, petrochemicals, plastics, semiconductors and wood composites as well as food processing, vacuum furnace applications and many other general applications in industry.

### Mechanical Seals

These series incorporate mechanical sealing on the rotor shafts and the drive shaft, flanged port fittings, water cooled drive shaft seal, and cooling coils in the end covers. Water cooled drive shaft seal not included with optional motor mounting flange versions.

### Slinger Seals

These series utilize a mechanical drive shaft seal in conjunction with a non-contacting, non-wearing slinger seal on the rotor shafts, water cooled drive shaft seal, flanged port fittings, and are dependable performers for air and many gas applications. Cooling coils are not included. Water cooled drive shaft seal not included with optional motor mounting flange versions.

### Optional Materials and Coatings Available

Standard construction materials include cast iron housing, end plates and port fittings with ductile iron rotors and shafts. In addition to standard construction, the following materials are available:

#### Special Materials

Ductile Iron

Carbon Steel\*

Stainless Steel\*

\*240 and 400 only

#### Special Coatings

Bi-Protec® (Nickel/Armoly®)

### Low Mechanical Noise

Every M-D Pneumatics vacuum booster is designed to operate at 82 dB(A) or less at blank-off (open field; motor and background noise excluded).



### Optional Motor Mounting Flanges

All models are available with flange adapters for mounting either a NEMA C-face motor (up to 75 HP) or an IEC D-flange motor (up to 55 kW) directly to the vacuum booster, eliminating the need for a separate base mounted assembly and coupling guard for the vacuum booster.

### Metric Availability

All M-D Pneumatics vacuum boosters are available with metric drive shaft and process connections.

### Material Specifications:

**Housing:** Cast iron

**End Plates:** Cast iron

**End Covers:** Cast iron

**Rotors:** Ductile iron

**Shafts:** Ductile iron cast integrally with rotors

**Drive Shaft:** Ductile iron

**Bearings:** Gear end - Double row ball, both rotors

Back end - Cylindrical roller

**Drive Shaft:** Double row ball

**Gears:** Alloy steel, helical cut and precision ground

**Seals:** Drive shaft - Mechanical

Rotor shafts - Mechanical or Non-contacting slinger

**Lubrication:** Oil splash system, both ends

MODEL	Net Wgt. (lbs.)*
150	150
240	200
400	270

\*Approximate shipping weight.

## Dimensions

Values shown are approximate and should not be used for construction.

Certified drawings are available through your local Tuthill Vacuum & Blower Systems Sales Professional.

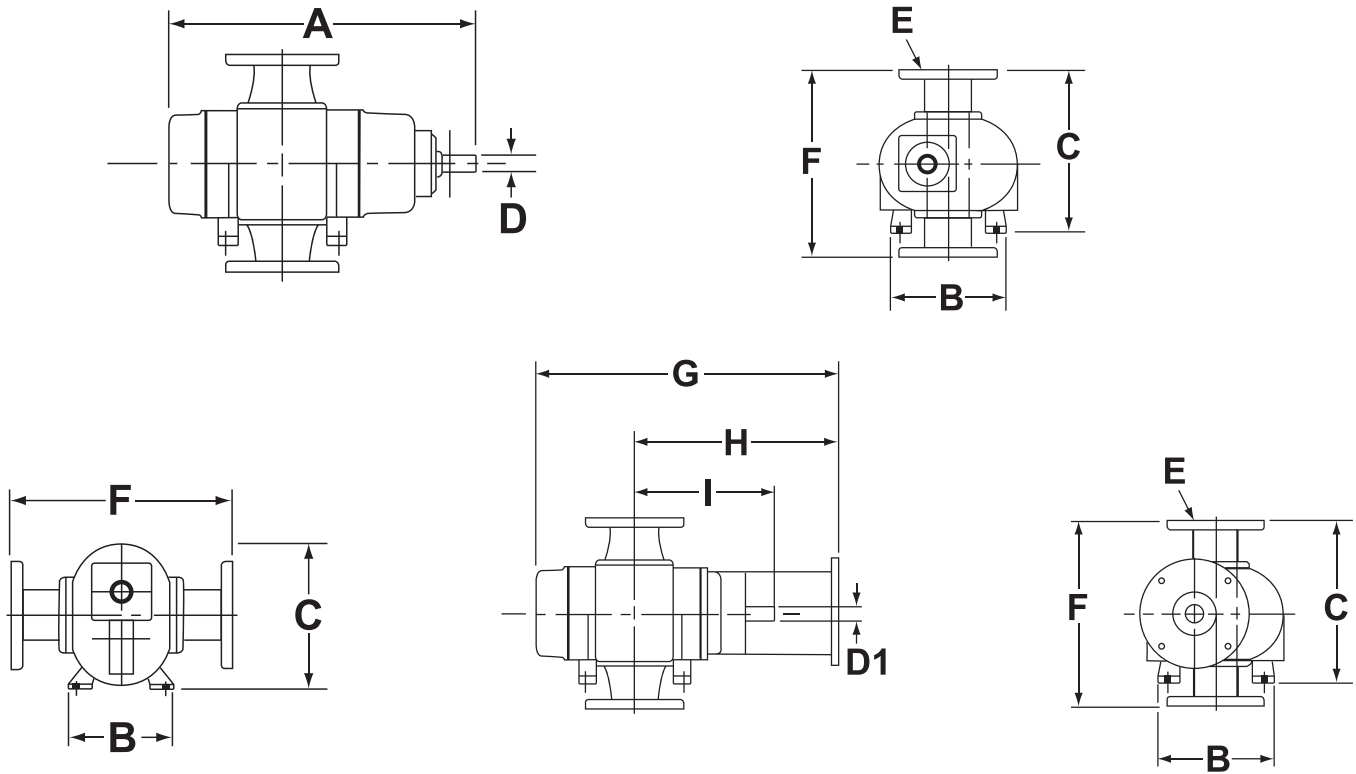

MODEL	DISPL. CFM	A	B	C	D Ø	D1 Ø	E	F	G	H	I
150	50-150	18.63	9.00	12.13	1.125	.875	2" FLG	13.25	20.69	14.06	11.00
		19.25	7.00	10.06							
240	70-230	20.63	9.00	12.94	1.125	.875	3" FLG	14.88	22.69	15.06	12.00
		21.25	7.00	10.06							
400	120-400	24.63	9.00	12.94	1.125	.875	4" FLG	14.88	26.69	17.06	14.00
		25.25	7.00	10.06							

\* The shaft diameters identified as "D1" apply only to C-Face vacuum boosters.

Your Local Tuthill Vacuum Blower Systems Sales Professional:



**Tuthill Vacuum & Blower Systems**  
 4840 West Kearney Street  
 Springfield, Missouri USA 65803-8702  
 o 417.865.8715 800.825.6937 f 417.865.2950  
 tuthillvacuumblower.com



TH-096 04/18